



# European GNSS (Galileo) Open Service

## Signal In Space Interface Control Document



Navigation solutions powered by Europe

# TERMS OF USE AND DISCLAIMERS

## 1. Authorised Use and Scope of Use

Note: The name “Galileo” shall mean the system established under the Galileo programme.

The European GNSS (Galileo) Open Service Signal In Space Interface Control Document Issue 1.2 (hereinafter referred to as OS SIS ICD) and the information contained herein is made available to the public by the European Union (hereinafter referred to as Publishing Authority) for information, standardization, research and development and commercial purposes for the benefit and the promotion of the European Global Navigation Satellite Systems programmes (European GNSS Programmes) and according to terms and conditions specified thereafter.

## 2. General Disclaimer of Liability as to Use

With respect to the OS SIS ICD and any information contained in the OS SIS ICD, neither the Publishing Authority nor the copyright holders nor the generator of such information make any warranty, express or implied, including the warranty of fitness for a particular purpose, or assumes any legal liability or responsibility for the accuracy, completeness, or usefulness of any information hereby disclosed or for any product developed based on this information, or represents that the use of this information would not cause damages or would not infringe any intellectual property rights. No liability is hereby assumed for any direct, indirect, incidental, special or consequential damages, including but not limited to, damages for interruption of business, loss of profits, goodwill or other intangible losses, resulting from the use of the OS SIS ICD or of the information contained herein. Liability is excluded as well for consequences of the use and / or abuse of the OS SIS ICD or the information contained herein.

## 3. Disclaimers as to Intellectual Property Rights

The information contained in the OS SIS ICD, including its Annexes, is subject to intellectual property rights (hereinafter referred to as IPR).

### Copyright

The OS SIS ICD is protected by copyright. Any alteration or translation in any language of the OS SIS ICD as a whole or parts of it is prohibited unless the Publishing Authority provides a specific written prior permission. The OS SIS ICD may only be partly or wholly reproduced and/or transmitted to a third party for non-profit purposes, in accordance with the herein described permitted use and under the following conditions:

- the present “Terms of Use and Disclaimers” are accepted, reproduced and transmitted entirely and unmodified together with the reproduced and/or transmitted information;
- the copyright notice “© European Union 2014” is not removed from any page.

## 4. Licence for OS SIS ICD Intellectual Property Rights

The use of the information contained in the OS SIS ICD, including the spreading codes which are subject to IPR, is hereby allowed for research and development on, manufacturing, commercialisation, distribution, sale, supply and maintenance of electronic devices (e.g. chipsets and receivers) and supply of Value Added Services according to the terms and conditions of the license agreement attached hereto as Annex D.

Such licences will be provided on a non-discriminatory basis in accordance with European Union rules and international commitments taken within the framework of the European GNSS Programmes.

Any interested party should contact: [oss-icd@ec.europa.eu](mailto:oss-icd@ec.europa.eu)

## 5. Miscellaneous

The publication or provision of the OS SIS ICD or the information contained herein shall not be construed as granting any implied IPR licence.

No failure or delay in exercising any right in relation to the OS SIS ICD or the information contained therein shall operate as a waiver thereof, nor shall any single or partial exercise preclude any other or further exercise of such rights.

The disclaimers contained in this document apply to the extent permitted by applicable law.

## 6. Updates

The OS SIS ICD in its current version could be subject to modification, update, and variations.

The publication of updates will be subject to the same terms as stated herein unless otherwise evidenced.

Although the Publishing Authority will deploy its efforts to give notice to the public for further updates of OS SIS ICD, it does not assume any obligation to advise on further developments and updates of the OS SIS ICD, nor to take into account any inputs, comments proposed by interested persons or entities, involved in the updating process.

## Document Change Record

Reason for change	Issue	Revision	Date
First issue	Draft	0	May 2006
CBOC Modulation added, 'lossless atmosphere' assumption removed from Tx power definition (issue under study), SAR data, update of the bit allocations of some F/NAV and I/NAV pages, editorial corrections etc.	Draft	1	February 2008
Update of the 'Terms of Use and Disclaimers' section and namely the licensing policy for R&D and standardization purposes as well as commercial purposes. Assignment of the primary and secondary codes to satellites in section in section 3.6. More details on the I/NAV alert page content in section 4.3.2.3. Clarification of the power sharing between the different Galileo signal components in section 2.7.1. Addition of Galileo E1 sub-carriers plots in section 2.3.3 Clarification that Galileo E5a and E5b signals can be processed as QPSK signals in section 2.3.1.2. Update of the acronym list with QPSK in annex A. In section 4.2.4, for Page Type 6, parameter 'i' has been replaced by $\omega$ , the argument of perigee. In section 5.1.2, Time of Week an entire week from 0 to 604799 seconds, not up to 604800.	Issue 1	0	February 2010
Licence Agreement has been made easier to be adopted by licensees. Terms of use and disclaimers have been amended accordingly.	Issue 1	1	September 2010
<b>Main updates:</b> Update of the constellation description and Earth radius in section 1.3. Correction of DCX-Y and rectT(t) definitions in Table 3. E1-B, E1-C and E5 Primary Codes now delivered only in the electronic version of this ICD: sections 3.4.1 and 3.4.2, Annex C. Secondary Codes CS10037 to CS10039 added in Table 19. I/NAV usage updated in section 4.1.1. Correction of "Dummy Data (2/2)" bits allocation in Table 50. Correction of "start bit" value (equal 0 instead of 1) in part (5/8) of long RLM in Table 55. Added "start bit" value (equal 1) in Table 56. Correction of "GTRF coordinates" formula in Table 58 (last row): "y" is the sum of the two terms. Updated description of GST start epoch in section 5.1.2. Clarification of "Day Number" value range in Table 65. Confirmation of "Data validity Status Bit" values in Table 71. Updates of section 5.2 relevant to the SAR Return Link Message to include RLM data content.	Issue 1	2	February 2014

Reason for change	Issue	Revision	Date
<p><b>Other revisions:</b></p> <p>Figure 8 improved and chart titles modified.</p> <p>Use of the expression XOR instead of EXOR in Figure 10 “LFSR Based Code Generator for Truncated and Combined M-sequences”.</p> <p>Removal of references to “E5 memory codes” in section 3.4.1 and title 8 as the E5 spreading codes are not memory codes but rather generated from LFSR sequences.</p> <p>Removal of references to the “Galileo L1 signals” as this notation is incorrect and the signals should be referred to as E1 signals (in section 3.6.1; in section 3.6.2 and in Equation 10 p 8).</p> <p>Introduction of additional explanatory sentences for Figure 13. “Convolutional Coding Scheme” and Table 37. “I/Nav Nominal Sub-Frame Structure”.</p> <p>Table 37 updated: one word and one number added respectively in row 27 and 30.</p> <p>Correction of expression “<math>(\Delta A)1/2</math>”(Difference with respect to the square root of the nominal semi-major axis) of Table 45 and “<math>\Delta(A1/2)</math>” of Tables 46 and 47 into the correct expression “<math>\Delta(A1/2)</math>”</p> <p>Clarification of the way a SAR receiver identifies SAR data belonging to SAR Return Link Message in Section 4.3.7 (subsection “Spare SAR Data”).</p> <p>Clarification of the boundaries of the region for the Ionospheric disturbance flag (MODIP <math>\epsilon</math> {90°; 60°; 30°; -30°; -60°; -90°}) at the end of section 5.1.6.</p> <p>Added footnotes in Tables 57 and 75 for the description of the longitude “Omega zero”.</p> <p>Table 65 moved from section 5.1.8 to section 5.1.7.</p> <p>Revision of Annex A (List of Acronyms) and Annex B (Definitions and Nomenclature).</p> <p>Miscellaneous minor typographical and wording corrections.</p> <p>Revisions are made visible with vertical bars in page margins.</p>			

**DRAFT**  
**For Public Consultation**

# Table of Contents

<b>1. Introduction</b>	<b>1</b>
1.1. Document Scope	1
1.2. Document Overview	1
1.3. Galileo System Overview	1
<b>2. Galileo Signal Characteristics</b>	<b>2</b>
2.1. Frequency Plan	2
2.1.1. Frequency Bands	2
2.1.2. Carrier Frequencies	2
2.1.3. Receiver Reference Bandwidths	2
2.2. Signal Polarization	3
2.3. Modulation	3
2.3.1. E5 Signal	4
2.3.1.1. Modulation Scheme	4
2.3.1.2. Modulation Type	5
2.3.1.3. Equivalent Modulation Type	6
2.3.2. E6 Signal	7
2.3.3. E1 Signal	8
2.4. Logic Levels	9
2.5. Transmitted Signal Phase Noise	10
2.6. Transmitted Signals Code/Data Coherency	10
2.7. Received Power Levels on Ground	10
2.7.1. Minimum Levels	10
2.7.2. Maximum Levels	10
2.8. Payload and Component Reception Losses	10
<b>3. Galileo Spreading Codes Characteristics</b>	<b>12</b>
3.1. Code Lengths	12
3.2. Tiered Codes Generation	12
3.3. Primary Codes Generation	13
3.4. Primary Codes Definition	13
3.4.1. E5 Primary Codes	13
3.4.1.1. Base Register 2 Start Value for E5a-I	14
3.4.1.2. Base Register 2 Start Value for E5a-Q	15
3.4.1.3. Base Register 2 Start Value for E5b-I	16
3.4.1.4. Base Register 2 Start Value for E5b-Q	17
3.4.2. E1-B and E1-C Primary Codes	18
3.5. Secondary Codes	18
3.5.1. Definition of Secondary Codes	18
3.5.2. Secondary Codes Assignment	21
3.6. Code Assignments to Satellites	22
3.6.1. Primary code assignment to satellites	22
3.6.2. Secondary code assignment to satellites	22
<b>4. Galileo Message Structure</b>	<b>23</b>
4.1. General Message Format Specification	23
4.1.1. General Navigation Message Content	23
4.1.2. General Navigation Message Structure	23
4.1.3. Bit and Byte Ordering Criteria	23

4.1.4.	<i>FEC Coding and Interleaving Parameters</i> .....	23
4.1.4.1.	<i>FEC Encoding</i> .....	23
4.1.4.2.	<i>Interleaving</i> .....	24
4.1.5.	<i>Frame and Page Timing</i> .....	24
<b>4.2.</b>	<b><i>F/NAV Message Description</i></b> .....	<b>24</b>
4.2.1.	<i>General Description of the F/NAV Message</i> .....	24
4.2.2.	<i>F/NAV Page Layout</i> .....	25
4.2.2.1.	<i>Synchronisation Pattern</i> .....	25
4.2.2.2.	<i>Tail Bits</i> .....	25
4.2.2.3.	<i>F/NAV Word</i> .....	25
4.2.3.	<i>F/NAV Frame Layout</i> .....	25
4.2.4.	<i>F/NAV Page Contents</i> .....	27
4.2.5.	<i>F/NAV Dummy Page Definition</i> .....	29
<b>4.3.</b>	<b><i>I/NAV Message Description</i></b> .....	<b>29</b>
4.3.1.	<i>General Description of the I/NAV Message</i> .....	29
4.3.2.	<i>I/NAV Page Layout</i> .....	29
4.3.2.1.	<i>Synchronisation Pattern</i> .....	30
4.3.2.2.	<i>Tail Bits</i> .....	30
4.3.2.3.	<i>I/NAV Page Part</i> .....	30
4.3.3.	<i>I/NAV Nominal Sub-Frame Layout</i> .....	32
4.3.4.	<i>I/NAV Nominal Frame Layout</i> .....	33
4.3.5.	<i>I/NAV Word Types</i> .....	34
4.3.6.	<i>I/NAV Dummy Message Layout</i> .....	37
4.3.7.	<i>SAR Field Structure</i> .....	38
<b>5.</b>	<b><i>Message Data Contents</i></b> .....	<b>40</b>
<b>5.1.</b>	<b><i>Navigation Data</i></b> .....	<b>40</b>
5.1.1.	<i>Ephemeris</i> .....	40
5.1.2.	<i>Galileo System Time (GST)</i> .....	42
5.1.3.	<i>Clock Correction Parameters</i> .....	43
5.1.4.	<i>Satellite Time Correction Algorithm</i> .....	43
5.1.5.	<i>Broadcast Group Delay</i> .....	44
5.1.6.	<i>Ionospheric Correction</i> .....	45
5.1.7.	<i>GST-UTC Conversion Algorithm and Parameters</i> .....	46
5.1.8.	<i>GPS to Galileo System Time Conversion and Parameters</i> .....	47
5.1.9.	<i>Service Parameters</i> .....	47
5.1.9.1.	<i>Satellite ID</i> .....	47
5.1.9.2.	<i>Issue Of Data</i> .....	48
5.1.9.3.	<i>Navigation Data Validity and Signal Health Status</i> .....	48
5.1.9.4.	<i>Checksum</i> .....	49
5.1.10.	<i>Almanac</i> .....	50
5.1.11.	<i>Signal – n63Space Accuracy (SISA)</i> .....	51
<b>5.2.</b>	<b><i>SAR RLM Data</i></b> .....	<b>51</b>
<b>6.</b>	<b><i>Annex A - List of Acronyms</i></b> .....	<b>53</b>
<b>7.</b>	<b><i>Annex B - Definitions and Nomenclature</i></b> .....	<b>55</b>



8. Annex C - Galileo E1 and E5 Primary Codes.....56  
C.1. Introduction..... 56  
C.2. Hexadecimal Coding Convention ..... 56  
9. Annex D - Licence Agreement .....57  
Annex D.1 - List of OS SIS ICD Related Intellectual Property Rights..... 62

**DRAFT**  
**For Public Consultation**

## List of Figures

Figure 1.	Space Vehicle/Navigation User Interface.....	1
Figure 2.	Galileo Frequency Plan.....	2
Figure 3.	Modulation Scheme for the E5 Signal .....	4
Figure 4.	One Period of the Two Sub-carrier Functions Involved in AltBOC Modulation.....	6
Figure 5.	8-PSK Phase-State Diagram of E5 AltBOC Signal.....	6
Figure 6.	Modulation Scheme for the E6 Signal.....	7
Figure 7.	Modulation Scheme for the E1 CBOC Signal.....	8
Figure 8.	One period of the CBOC sub-carrier for a) the E1-B signal component, and b) the E1-C signal component.....	9
Figure 9.	Tiered Codes Generation .....	12
Figure 10.	LFSR Based Code Generator for Truncated and Combined M-sequences.....	13
Figure 11.	Code Register Feedback Taps Representation (example for E5a-I).....	14
Figure 12.	Start Value Representation for Base Register 2 (first code of E5a-I).....	14
Figure 13.	Convolutional Coding Scheme.....	24
Figure 14.	F/NAV Message Structure.....	25
Figure 15.	I/NAV Message Structure in the Nominal Mode.....	29

DRAFT  
For Public Consultation

## List of Tables

Table 1.	Carrier Frequency per Signal.....	2
Table 2.	Galileo Signals Receiver Reference Bandwidths.....	3
Table 3.	Signal Description Parameters.....	4
Table 4.	E5 Chip Rates and Symbol Rates.....	5
Table 5.	AltBOC Sub-carrier Coefficients.....	5
Table 6.	Look-up Table for AltBOC Phase States.....	7
Table 7.	E6 Chip Rates and Symbol Rates.....	7
Table 8.	E1 CBOC Chip Rates and Sub-carrier Rates.....	8
Table 9.	E1-B/C Symbol Rates.....	9
Table 10.	Logic to Signal Level Assignment.....	9
Table 11.	Received Minimum Power Levels on Ground.....	10
Table 12.	Additional Losses due to Receiver Filtering.....	11
Table 13.	Code Lengths.....	12
Table 14.	E5 Primary Codes Specifications.....	14
Table 15.	Base Register 2 Start Values and First Code Chip for E5a-I.....	15
Table 16.	Base Register 2 start Values and First Code Chip for E5a-Q.....	16
Table 17.	Base Register 2 Start Values and First Code Chip for E5b-I.....	17
Table 18.	Base Register 2 Start Values and First Code Chip for E5b-Q.....	18
Table 19.	Secondary Code Sequences (Part 1).....	20
Table 20.	Secondary Code Sequences (Part 2).....	21
Table 21.	Secondary Code Assignment.....	22
Table 22.	Message Allocation and General Data Content.....	23
Table 23.	Data Coding Parameters.....	24
Table 24.	Interleaving Parameters.....	24
Table 25.	F/NAV Page Layout.....	25
Table 26.	F/NAV Frame Layout.....	27
Table 27.	Bits Allocation for F/NAV Page Type 1.....	28
Table 28.	Bits Allocation for F/NAV Page Type 2.....	28
Table 29.	Bits Allocation for F/NAV Page Type 3.....	28
Table 30.	Bits Allocation for F/NAV Page Type 4.....	28
Table 31.	Bits Allocation for F/NAV Page Type 5.....	28
Table 32.	Bits Allocation for F/NAV Page Type 6.....	29
Table 33.	Bits Allocation for F/NAV Dummy Page.....	29
Table 34.	I/NAV Page Part Layout.....	30
Table 35.	I/NAV Nominal Page with Bits Allocation.....	30
Table 36.	I/NAV Alert Page with Bits Allocation.....	31
Table 37.	I/Nav Nominal Sub-Frame Structure.....	33
Table 38.	I/NAV Sub-Frame Sequencing.....	34
Table 39.	Bits Allocation for I/NAV Word Type 1.....	35
Table 40.	Bits Allocation for I/NAV Word Type 2.....	35
Table 41.	Bits Allocation for I/NAV Word Type 3.....	35
Table 42.	Bits Allocation for I/NAV Word Type 4.....	35
Table 43.	Bits Allocation for I/NAV Word Type 5.....	35
Table 44.	Bits Allocation for I/NAV Word Type 6.....	36
Table 45.	Bits Allocation for I/NAV Word Type 7.....	36
Table 46.	Bits Allocation for I/NAV Word Type 8.....	36
Table 47.	Bits Allocation for I/NAV Word Type 9.....	36
Table 48.	Bits Allocation for I/NAV Word Type 10.....	36
Table 49.	Bits Allocation for Spare Word.....	37
Table 50.	I/NAV Dummy Page with Bits Allocation.....	37
Table 51.	Dummy Word with Bits Allocation.....	38

Table 52.	SAR Field Bit Structure.....	38
Table 53.	RLM Identifier Description.....	38
Table 54.	SAR Short RLM.....	38
Table 55.	SAR Long RLM.....	39
Table 56.	Spare SAR Data.....	39
Table 57.	Ephemeris Parameters.....	41
Table 58.	User Algorithm for Ephemeris Determination.....	42
Table 59.	GST Parameters.....	42
Table 60.	Galileo Clock Correction Parameters.....	43
Table 61.	Galileo Clock Correction Data.....	43
Table 62.	BGD Parameters.....	44
Table 63.	BGD Values Mapping on Messages and Services.....	45
Table 64.	Ionospheric Correction Parameters.....	45
Table 65.	Parameters for the GST-UTC Conversion.....	46
Table 66.	Parameters for the GPS Time to GST Offset Computation.....	47
Table 67.	Satellite ID.....	47
Table 68.	IOD Values Mapping on Data Type.....	48
Table 69.	Data Validity Satellite Status (transmitted on E5a).....	48
Table 70.	Data Validity Satellite Status (transmitted on E5b and E1-B).....	48
Table 71.	Data validity Status Bit Values.....	49
Table 72.	Signal Health Status for E5a (transmitted on E5a).....	49
Table 73.	Signal Health Status for E5b and E1 (transmitted on E5b and E1-B).....	49
Table 74.	Signal Health Status Bit Values.....	49
Table 75.	Almanac Parameters.....	51
Table 76.	SISA Index Values.....	51
Table 77.	SISA Parameters.....	51
Table 78.	SAR RLM Message Code Values.....	52
Table 79.	SAR Short-RLM Data Values.....	52
Table 80.	Example for the Translation of Logical (binary) Spreading Code into Hexadecimal Representation.....	56
Table 81.	Primary Code-Length and Hexadecimal Representation Characteristics for the Galileo Signal Components.....	56

# 1. Introduction

## 1.1. Document Scope

The name “Galileo” shall mean the system established under the Galileo programme.

The present European GNSS (Galileo) Open Service Signal In Space Interface Control Document (OS SIS ICD) Issue 1.2 contains the publicly available information on the Galileo Signal In Space. It is intended for use by the Galileo user community and it specifies the interface between the Galileo Space Segment, and the Galileo User Segment.

## 1.2. Document Overview

The present document is organised as follows:

- Chapter 1 is this introduction which provides the scope of the document and an overview of the Galileo system
- Chapter 2 provides the signal-in-space radio frequency characteristics
- Chapter 3 provides the characteristics of the spreading codes
- Chapter 4 provides the message structures
- Chapter 5 provides the characteristics of the navigation message data contents

## 1.3. Galileo System Overview

Galileo is the European global navigation satellite system providing a highly accurate, and global, positioning service under civilian control. It is interoperable with GPS and GLONASS, the two other current global satellite navigation systems.

The fully deployed Galileo system consists of 24 operational satellites and up to 6 active spares, positioned in three circular Medium Earth Orbit planes. Each orbit has a nominal average semi-major axis of 29 600 km, and an inclination of the orbital plane of 56 degrees with reference to the equatorial plane.

Galileo provides enhanced distress localisation and call features for the provision of a Search and Rescue (SAR) service interoperable with the COSPAS-SARSAT system.

Figure 1 specifies the radio-frequency air interface between space and user segments. Three independent CDMA signals, named E5, E6 and E1, are permanently transmitted by all Galileo satellites. The E5 signal is further sub-divided into two signals denoted E5a and E5b.

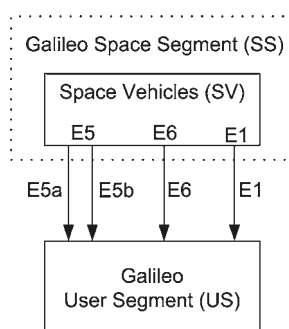

Figure 1. Space Vehicle/Navigation User Interface

## 2. Galileo Signal Characteristics

### 2.1. Frequency Plan

#### 2.1.1. Frequency Bands

The Galileo navigation Signals are transmitted in the four frequency bands indicated in Figure 2. These four frequency bands are the E5a, E5b, E6 and E1 bands. They provide a wide bandwidth for the transmission of the Galileo Signals.

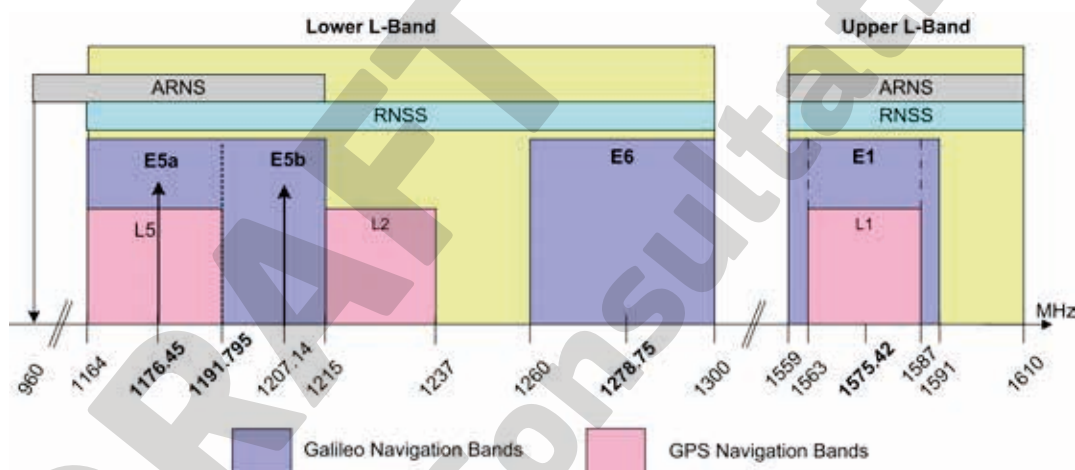

Figure 2. Galileo Frequency Plan

The Galileo frequency bands have been selected in the allocated spectrum for Radio Navigation Satellite Services (RNSS) and in addition to that, E5a, E5b and E1 bands are included in the allocated spectrum for Aeronautical Radio Navigation Services (ARNS), employed by Civil-Aviation users, and allowing dedicated safety-critical applications.

#### 2.1.2. Carrier Frequencies

Galileo carrier frequencies are shown in Table 1. The names of the Galileo signals are the same than the corresponding carrier frequencies.

Signal	Carrier Frequency (MHz)
E1	1575.420
E6	1278.750
E5	1191.795
E5a	1176.450
E5b	1207.140

Table 1. Carrier Frequency per Signal

Note: The E5a and E5b signals are part of the E5 signal in its full bandwidth.

#### 2.1.3. Receiver Reference Bandwidths

The receiver reference bandwidths centred on the carrier frequencies of Table 1 are specified in Table 2. Those reference bandwidths are considered when computing the correlation losses provided in paragraph 2.8.

Signal	Receiver Reference Bandwidth (MHz)
E1	24.552
E6	40.920
E5	51.150
E5a	20.460
E5b	20.460

Table 2. Galileo Signals Receiver Reference Bandwidths

## 2.2. Signal Polarization

The transmitted signals are Right-Hand Circularly Polarized (RHCP).

## 2.3. Modulation

In the following sections, modulation expressions are given for the power normalized complex envelope (i.e. base-band version)  $s_X(t)$  of a modulated (band-pass) signal  $S_X(t)$ . Both are described in terms of their in-phase  $s_{X-I}(t)$  and quadrature  $s_{X-Q}(t)$  components by the following generic expressions in Eq. 1.

$$S_X(t) = \sqrt{2P_X} [s_{X-I}(t) \cos(2\pi f_X t) - s_{X-Q}(t) \sin(2\pi f_X t)]$$

$$s_X(t) = s_{X-I}(t) + j s_{X-Q}(t)$$

Eq. 1

Table 3 defines the signal parameters used in this chapter, with the indices:

- 'X' accounting for the respective carrier (E5, E5a, E5b, E6 or E1) and
- 'Y' accounting for the respective signal component (B, C, I or Q) within the signal 'X'.

Parameter	Explanation	Unit
$f_X$	Carrier frequency	Hz
$P_X$	RF-Signal power	W
$L_{X-Y}$	Ranging code repetition period	chips
$T_{C,X-Y}$	Ranging code chip length	s
$T_{S,X}$	Sub-carrier period	s
$T_{S,X-Y}$	Sub-carrier period	s
$T_{D,X-Y}$	Navigation message symbol duration	s
$R_{C,X-Y}$	= $1/T_{C,X-Y}$ code chip rate	Hz
$R_{S,X}$	= $1/T_{S,X}$ sub-carrier frequency	Hz
$R_{S,X-Y}$	= $1/T_{S,X-Y}$ sub-carrier frequency	Hz
$R_{D,X-Y}$	= $1/T_{D,X-Y}$ navigation message symbol rate	Hz
$S_X(t)$	Signal band-pass representation	N/A
$C_{X-Y}(t)$	Binary (NRZ modulated) ranging code	N/A
$D_{X-Y}(t)$	Binary (NRZ modulated) navigation message signal	N/A
$sc_{X-Y}(t)$	Binary (NRZ modulated) sub-carrier	N/A
$e_{X-Y}(t)$	Binary NRZ modulated navigation signal component including code, sub-carrier (if available) and navigation message data (if available); (= $c_{X-Y}(t) sc_{X-Y}(t) D_{X-Y}(t)$ )	N/A

Parameter	Explanation	Unit
$s_X(t)$	Normalised (unit mean power) baseband signal $= s_{X-I}(t) + j s_{X-Q}(t)$	N/A
$c_{X-Y,k}$	$k^{\text{th}}$ chip of the ranging code	N/A
$d_{X-Y,k}$	$k^{\text{th}}$ symbol of the navigation message	N/A
$DC_{X-Y}$	$= T_{D,X-Y}/T_{C,X-Y}$ number of code chips per symbol	N/A
$ i _L$	$i$ modulo $L$	N/A
$[i]_{DC}$	Integer part of $i/DC$	N/A
$\text{rect}_T(t)$	Function "rectangle" which is equal to 1 for $0 \leq t < T$ and equal to 0 elsewhere	N/A

Table 3. Signal Description Parameters

### 2.3.1. E5 Signal

#### 2.3.1.1. Modulation Scheme

The diagram in Figure 3 provides a generic view of the E5 signal AltBOC modulation generation.

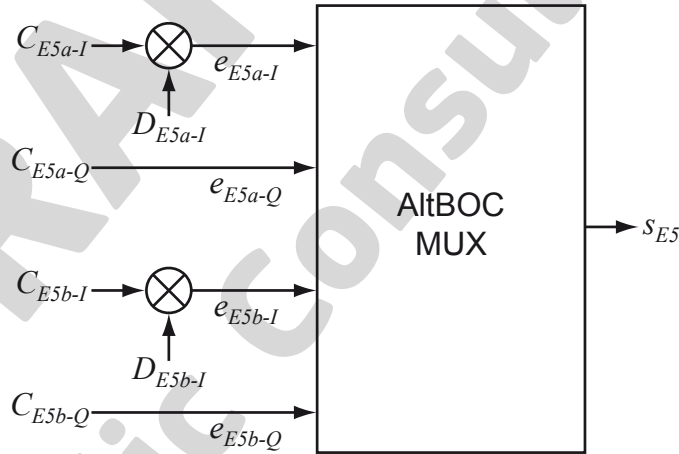

Figure 3. Modulation Scheme for the E5 Signal

The E5 signal components are generated according to the following:

- $e_{E5a-I}$  from the F/NAV navigation data stream  $D_{E5a-I}$  modulated with the unencrypted ranging code  $C_{E5a-I}$
- $e_{E5a-Q}$  (pilot component) from the unencrypted ranging code  $C_{E5a-Q}$
- $e_{E5b-I}$  from the I/NAV navigation data stream  $D_{E5b-I}$  modulated with the unencrypted ranging code  $C_{E5b-I}$
- $e_{E5b-Q}$  (pilot component) from the unencrypted ranging code  $C_{E5b-Q}$

The respective definitions are following (Eq. 2):

$$\begin{aligned}
 e_{E5a-I}(t) &= \sum_{i=-\infty}^{+\infty} \left[ c_{E5a-I, |i|_L} d_{E5a-I, [i]_{DC}} \text{rect}_{T_{C,E5a-I}}(t - iT_{C,E5a-I}) \right] \\
 e_{E5a-Q}(t) &= \sum_{i=-\infty}^{+\infty} \left[ c_{E5a-Q, |i|_L} \text{rect}_{T_{C,E5a-Q}}(t - iT_{C,E5a-Q}) \right] \\
 e_{E5b-I}(t) &= \sum_{i=-\infty}^{+\infty} \left[ c_{E5b-I, |i|_L} d_{E5b-I, [i]_{DC}} \text{rect}_{T_{C,E5b-I}}(t - iT_{C,E5b-I}) \right] \\
 e_{E5b-Q}(t) &= \sum_{i=-\infty}^{+\infty} \left[ c_{E5b-Q, |i|_L} \text{rect}_{T_{C,E5b-Q}}(t - iT_{C,E5b-Q}) \right]
 \end{aligned}$$

Eq. 2



The Galileo satellites transmit the E5 signal components with the ranging codes chip rates and symbol rates stated in Table 4.

Signal (Parameter X)	Component (Parameter Y)	Ranging Code Chip-Rate $R_{C,X-Y}$ (Mchip/s)	Symbol-Rate $R_{D,X-Y}$ (symbols/s)
E5a	I	10.230	50
	Q	10.230	No data ('pilot component')
E5b	I	10.230	250
	Q	10.230	No data ('pilot component')

Table 4. E5 Chip Rates and Symbol Rates

### 2.3.1.2. Modulation Type

The wideband E5 signal is generated with the AltBOC modulation of side-band sub-carrier rate  $R_{S,E5} = 1/T_{S,E5} = 15.345$  MHz ( $15 \times 1.023$  MHz) according to the expression in Eq. 3 with the binary signal components  $e_{E5a-I}$ ,  $e_{E5a-Q}$ ,  $e_{E5b-I}$  and  $e_{E5b-Q}$  as defined in Eq. 2. Note that E5a and E5b signals can be processed independently by the user receiver as though they were two separate QPSK signals with a carrier frequency of 1176.45 MHz and 1207.14 MHz respectively.

$$\begin{aligned}
 s_{E5}(t) = & \frac{1}{2\sqrt{2}} \left( e_{E5a-I}(t) + j e_{E5a-Q}(t) \right) \left[ sc_{E5-S}(t) - j sc_{E5-S}(t - T_{S,E5}/4) \right] + \\
 & \frac{1}{2\sqrt{2}} \left( e_{E5b-I}(t) + j e_{E5b-Q}(t) \right) \left[ sc_{E5-S}(t) - j sc_{E5-S}(t - T_{S,E5}/4) \right] + \\
 & \frac{1}{2\sqrt{2}} \left( \bar{e}_{E5a-I}(t) + j \bar{e}_{E5a-Q}(t) \right) \left[ sc_{E5-P}(t) - j sc_{E5-P}(t - T_{S,E5}/4) \right] + \\
 & \frac{1}{2\sqrt{2}} \left( \bar{e}_{E5b-I}(t) + j \bar{e}_{E5b-Q}(t) \right) \left[ sc_{E5-P}(t) - j sc_{E5-P}(t - T_{S,E5}/4) \right]
 \end{aligned}
 \tag{Eq. 3}$$

The respective dashed signal components  $\bar{e}_{E5a-I}$ ,  $\bar{e}_{E5a-Q}$ ,  $\bar{e}_{E5b-I}$  and  $\bar{e}_{E5b-Q}$  represent product signals according to Eq. 4:

$$\begin{aligned}
 \bar{e}_{E5a-I} &= e_{E5a-Q} e_{E5b-I} e_{E5b-Q} & \bar{e}_{E5b-I} &= e_{E5b-Q} e_{E5a-I} e_{E5a-Q} \\
 \bar{e}_{E5a-Q} &= e_{E5a-I} e_{E5b-I} e_{E5b-Q} & \bar{e}_{E5b-Q} &= e_{E5b-I} e_{E5a-I} e_{E5a-Q}
 \end{aligned}
 \tag{Eq. 4}$$

The parameters  $sc_{E5-S}$  and  $sc_{E5-P}$  represent the four-valued sub-carrier functions for the single signals and the product signals respectively:

$$\begin{aligned}
 sc_{E5-S}(t) &= \sum_{i=-\infty}^{\infty} AS_{|i|_8} \text{rect}_{T_{S,E5}/8}(t - iT_{S,E5}/8) \\
 sc_{E5-P}(t) &= \sum_{i=-\infty}^{\infty} AP_{|i|_8} \text{rect}_{T_{S,E5}/8}(t - iT_{S,E5}/8)
 \end{aligned}
 \tag{Eq. 5}$$

The coefficients  $AS_i$  and  $AP_i$  are according to Table 5.

$i$	0	1	2	3	4	5	6	7
$2 \cdot AS_i$	$\sqrt{2} + 1$	1	-1	$-\sqrt{2} - 1$	$-\sqrt{2} - 1$	-1	1	$\sqrt{2} + 1$
$2 \cdot AP_i$	$-\sqrt{2} + 1$	1	-1	$\sqrt{2} - 1$	$\sqrt{2} - 1$	-1	1	$-\sqrt{2} + 1$

Table 5. AltBOC Sub-carrier Coefficients

One period of the sub-carrier functions  $sc_{E5-S}$  and  $sc_{E5-P}$  is shown in Figure 4.

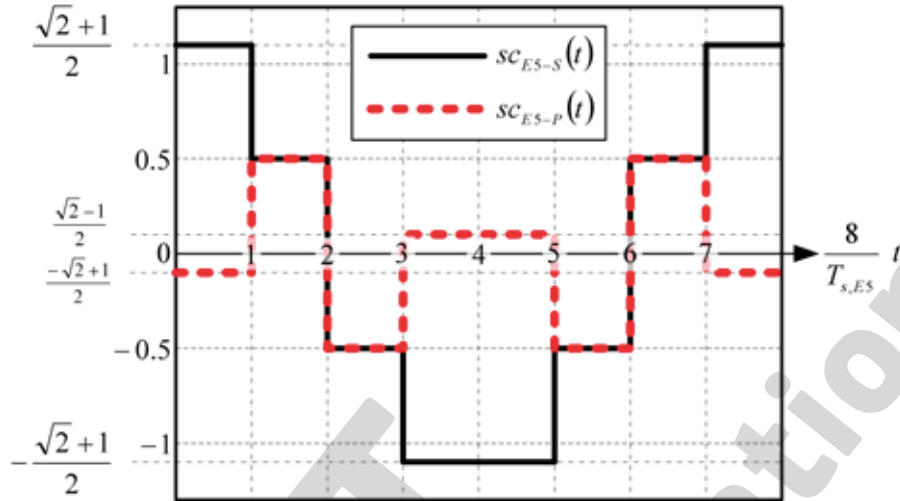

Figure 4. One Period of the Two Sub-carrier Functions Involved in AltBOC Modulation

### 2.3.1.3. Equivalent Modulation Type

Equivalently, the AltBOC complex baseband signal  $s_{E5}(t)$  can be described as an 8-PSK signal according to Eq. 6. The corresponding phase states are illustrated in Figure 5.

$$s_{E5}(t) = \exp\left(j \frac{\pi}{4} k(t)\right) \quad \text{with} \quad k(t) \in \{1,2,3,4,5,6,7,8\}, \quad \text{Eq. 6}$$

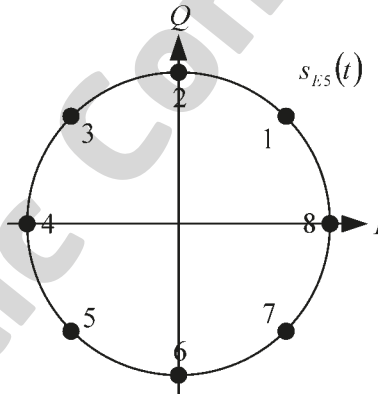

Figure 5. 8-PSK Phase-State Diagram of E5 AltBOC Signal

The relation of the 8 phase states to the 16 different possible states of the quadruple  $e_{E5a-I}(t)$ ,  $e_{E5a-Q}(t)$ ,  $e_{E5b-I}(t)$ , and  $e_{E5b-Q}(t)$  depends also on time. Therefore, time is partitioned first in sub-carrier intervals  $T_{s,E5}$  and further sub-divided in 8 equal sub-periods. The index  $i_{T_s}$  of the actual sub-period is given by Eq. 7 and determines which relation between input quadruple and phase states has to be used.

$$i_{T_s} = \text{integer part} \left[ \frac{8}{T_{s,E5}} (t \text{ modulo } T_{s,E5}) \right] \quad \text{with} \quad i_{T_s} \in \{0,1,2,3,4,5,6,7\} \quad \text{Eq. 7}$$

The dependency of phase-states from input-quadruples and time is given in Table 6.

		Input Quadruples															
eE5a-I		-1	-1	-1	-1	-1	-1	-1	-1	1	1	1	1	1	1	1	1
eE5b-I		-1	-1	-1	-1	1	1	1	1	-1	-1	-1	-1	1	1	1	1
eE5a-Q		-1	-1	1	1	-1	-1	1	1	-1	-1	1	1	-1	-1	1	1
eE5b-Q		-1	1	-1	1	-1	1	-1	1	-1	1	-1	1	-1	1	-1	1
$t' = t \text{ modulo } T_{s,E5}$		$k$ according to $s_{E5}(t) = \exp(jk\pi/4)$															
$i_{T_s}$	$t'$																
0	$[0, T_{s,E5}/8[$	5	4	4	3	6	3	1	2	6	5	7	2	7	8	8	1
1	$[T_{s,E5}/8, 2 T_{s,E5}/8[$	5	4	8	3	2	3	1	2	6	5	7	6	7	4	8	1
2	$[2 T_{s,E5}/8, 3 T_{s,E5}/8[$	1	4	8	7	2	3	1	2	6	5	7	6	3	4	8	5
3	$[3 T_{s,E5}/8, 4 T_{s,E5}/8[$	1	8	8	7	2	3	1	6	2	5	7	6	3	4	4	5
4	$[4 T_{s,E5}/8, 5 T_{s,E5}/8[$	1	8	8	7	2	7	5	6	2	1	3	6	3	4	4	5
5	$[5 T_{s,E5}/8, 6 T_{s,E5}/8[$	1	8	4	7	6	7	5	6	2	1	3	2	3	8	4	5
6	$[6 T_{s,E5}/8, 7 T_{s,E5}/8[$	5	8	4	3	6	7	5	6	2	1	3	2	7	8	4	1
7	$[7 T_{s,E5}/8, T_{s,E5}[$	5	4	4	3	6	7	5	2	6	1	3	2	7	8	8	1

Table 6. Look-up Table for AltBOC Phase States

### 2.3.2. E6 Signal

Figure 6 provides a generic view of the E6 signal generation.

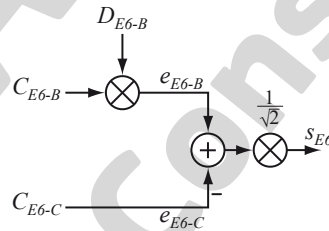

Figure 6. Modulation Scheme for the E6 Signal

The E6 signal B and C components are generated according to the following

- $e_{E6-B}$  from the C/NAV navigation data stream  $D_{E6-B}$  modulated with the encrypted ranging code  $C_{E6-B}$
- $e_{E6-C}$  (pilot component) from the ranging code  $C_{E6-C}$

Equation 8 provides their mathematical description.

$$e_{E6-B}(t) = \sum_{i=-\infty}^{+\infty} \left[ c_{E6-B,|i|L_{E6-B}} d_{E6-B,|i|DC_{E6-B}} \text{rect}_{T_{C,E6-B}}(t - iT_{C,E6-B}) \right]$$

$$e_{E6-C}(t) = \sum_{i=-\infty}^{+\infty} \left[ c_{E6-C,|i|L_{E6-C}} \text{rect}_{T_{C,E6-C}}(t - iT_{C,E6-C}) \right]$$

Eq. 8

The Galileo satellites transmit the E6 signal components with the ranging codes chip rates and symbol rates stated in Table 7.

Component (Parameter Y)	Ranging Code Chip-Rate $R_{C,E6-Y}$ (MChip/s)	Symbol-Rate $R_{D,E6-Y}$ (symbols/s)
B	5.115	1000
C	5.115	No data ('pilot component')

Table 7. E6 Chip Rates and Symbol Rates

The E6 signal is generated according to Eq. 9, with the binary signal components  $e_{E6-B}(t)$  and  $e_{E6-C}(t)$ .

$$s_{E6}(t) = \frac{1}{\sqrt{2}} [e_{E6-B}(t) - e_{E6-C}(t)] \quad \text{Eq. 9}$$

Note: both pilot and data components are combined on the same carrier component, with a power sharing of 50 percent.

### 2.3.3. E1 Signal

Figure 7 provides a generic view of the E1 CBOC signal generation.

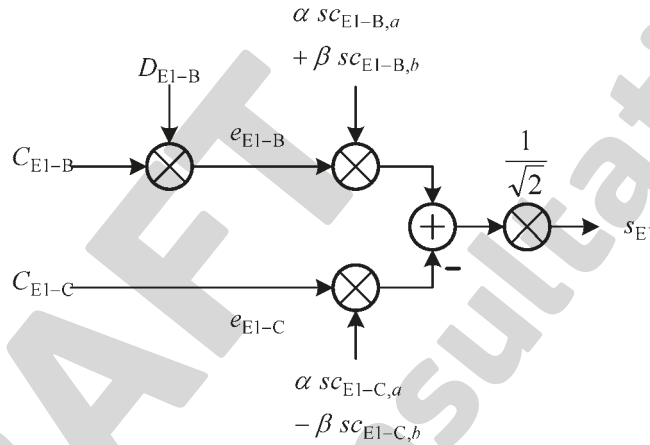

Figure 7. Modulation Scheme for the E1 CBOC Signal

The E1 CBOC signal components are generated as follows:

- $e_{E1-B}$  from the I/NAV navigation data stream  $D_{E1-B}$  and the ranging code  $C_{E1-B}$ , then modulated with the sub-carriers  $s_{C_{E1-B},a}$  and  $s_{C_{E1-B},b}$
- $e_{E1-C}$  (pilot component) from the ranging code  $C_{E1-C}$  including its secondary code, then modulated with the sub-carriers  $s_{C_{E1-C},a}$  and  $s_{C_{E1-C},b}$

Equation 10 provides the mathematical description of these components.

$$e_{E1-B}(t) = \sum_{i=-\infty}^{\infty} [c_{E1-B,|i|L_{E1-B}} D_{E1-B,|i|D_{C_{E1-B}}} \text{rect}_{T_{c,E1-B}}(t - iT_{c,E1-B})] \quad \text{Eq.10}$$

$$e_{E1-C}(t) = \sum_{i=-\infty}^{\infty} [c_{E1-C,|i|L_{E1-C}} \text{rect}_{T_{c,E1-C}}(t - iT_{c,E1-C})]$$

Galileo satellites transmit ranging signals for the E1 signal with the chip rates and sub-carrier rates defined in the following Table 8.

Component (Parameter Y)	Sub-carrier Type	Sub-carrier Rate		Ranging Code Chip-Rate $R_{C,E1-Y}$ (Mcps)
		$R_{S,E1-Y,a}$ (MHz)	$R_{S,E1-Y,b}$ (MHz)	
B	CBOC, in-phase	1.023	6.138	1.023
C	CBOC, anti-phase	1.023	6.138	1.023

Table 8. E1 CBOC Chip Rates and Sub-carrier Rates

The navigation data message stream, after channel encoding, is transmitted with the symbol rate as stated in Table 9.

Component (Parameter Y)	Symbol Rate $R_{D,EI-Y}$ (symbols/s)
B	250
C	No data ('pilot component')

Table 9. E1-B/C Symbol Rates

The E1-B/C composite signal is then generated according to equation Eq. 11 below, with the binary signal components  $e_{E1-B}(t)$  and  $e_{E1-C}(t)$ . Note that as for E6, both pilot and data components are modulated onto the same carrier component, with a power sharing of 50 percent.

$$s_{E1}(t) = \frac{1}{\sqrt{2}} \left( e_{E1-B}(t) \left( \alpha sc_{E1-B,a}(t) + \beta sc_{E1-B,b}(t) \right) - e_{E1-C}(t) \left( \alpha sc_{E1-C,a}(t) - \beta sc_{E1-C,b}(t) \right) \right) \quad \text{Eq. 11}$$

$$\text{with } sc_x(t) = \text{sgn}(\sin(2\pi R_{s,x}t))$$

The parameters  $\alpha$  and  $\beta$  are chosen such that the combined power of the  $sc_{E1-B,b}$  and the  $sc_{E1-C,b}$  sub carrier components equals 1/11 of the total power of  $e_{E1-B}$  plus  $e_{E1-C}$  before application of any bandwidth limitation. This yields:

$$\alpha = \sqrt{\frac{10}{11}} \quad \text{and} \quad \beta = \sqrt{\frac{1}{11}}$$

One period of the sub-carrier function  $\alpha sc_{E1-B,a}(t) + \beta sc_{E1-B,b}(t)$  for the E1-B signal component and one period of the sub-carrier function  $\alpha sc_{E1-C,a}(t) - \beta sc_{E1-C,b}(t)$  for the E1-C signal component are shown in the following figure

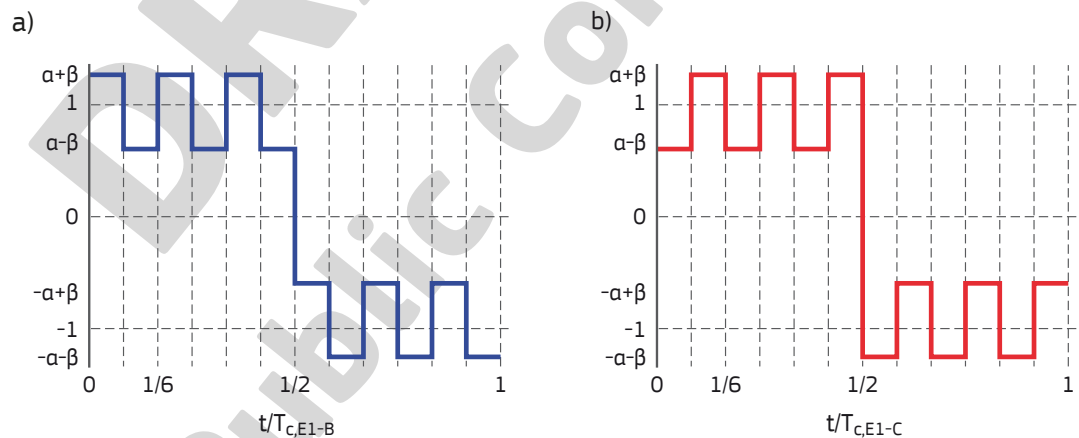

Figure 8. One period of the CBOC sub-carrier for a) the E1-B signal component, and b) the E1-C signal component

## 2.4. Logic Levels

The correspondence between the logic level code bits used to modulate the signal and the signal level is according to the values stated in Table 10.

Logic Level	Signal Level
1	-1.0
0	+1.0

Table 10. Logic to Signal Level Assignment

## 2.5. Transmitted Signal Phase Noise

The phase noise spectral density of the un-modulated carrier will allow a second-order phase locked loop with 10 Hz one-sided noise bandwidth to track the carrier to an accuracy of 0.04 radians RMS.

## 2.6. Transmitted Signals Code/Data Coherency

The edge of each data symbol coincides with the edge of a code chip. Periodic spreading codes start coincides with the start of a data symbol.

The edge of each secondary code chip coincides with the edge of a primary code chip. Primary code start coincides with the start of a secondary code chip.

## 2.7. Received Power Levels on Ground

### 2.7.1. Minimum Levels

The Galileo satellites will provide Galileo E5, E6 and E1 signals strength in order to meet the minimum levels specified in Table 11. The minimum received power on ground is measured at the output of an ideally matched RHCP 0 dBi polarized user receiving antenna when the SV elevation angle is higher than 10 degrees.

Signal	Signal Component	Total Received Minimum Power (dBW)
E5	E5a (total I+Q) (50/50% I/Q power sharing)	-155
	E5b (total I+Q) (50/50% I/Q power sharing)	-155
E6	E6-B/C (total B+C) (50/50% E6-B/E6-C power sharing)	-155
E1	E1-B/C (total B+C) (50/50% E1-B/E1-C power sharing)	-157

Table 11. Received Minimum Power Levels on Ground

For a 5 degree user elevation angle, the user minimum received power will typically be 0.25 dB lower than specified in Table 11 above.

### 2.7.2. Maximum Levels

The Galileo terrestrial user's maximum received signal power level is, using the same assumptions as for the minimum received power, not expected to exceed 3 dB above the corresponding minimum received power.

For purposes of establishing user receiver dynamic range for receiver design and test, the maximum received signal power level is not expected to exceed 7 dB above the corresponding minimum received power.

## 2.8. Payload and Component Reception Losses

The correlation loss due to payload distortions will be below 0.6 dB.

For the reference receiver bandwidths defined in section 2.1.3, additional losses due to receiver filtering are to be considered, as shown in Table 12.

Signal	Loss (dB)
E1	0.1
E6	0.0
E5	0.4
E5a	0.6
E5b	0.6

Table 12. Additional Losses due to Receiver Filtering

**DRAFT**  
**For Public Consultation**

### 3. Galileo Spreading Codes Characteristics

#### 3.1. Code Lengths

The ranging codes are built from so-called primary and secondary codes by using a tiered codes construction described in paragraph 3.2. The code lengths to be used for each signal component are stated in Table 13. Note that the E6 ranging codes are not subject of this SIS ICD.

Signal Component	Tiered Code Period (ms)	Code Length (chips)	
		Primary	Secondary
E5a-I	20	10230	20
E5a-Q	100	10230	100
E5b-I	4	10230	4
E5b-Q	100	10230	100
E1-B	4	4092	N/A
E1-C	100	4092	25

Table 13. Code Lengths

#### 3.2. Tiered Codes Generation

Long spreading codes are generated by a tiered code construction, whereby a secondary code sequence is used to modify successive repetitions of a primary code, as shown in Figure 9 for a primary code of length  $N$  and chip rate  $f_c$ , and a secondary code of length  $N_s$  and chip rate  $f_{cs} = f_c/N$ . The duration of  $N$  chips is also called a primary code epoch in Figure 9. In logical representation, the secondary code chips are sequentially exclusive-ored with the primary code, always one chip of the secondary code per period of the primary code.

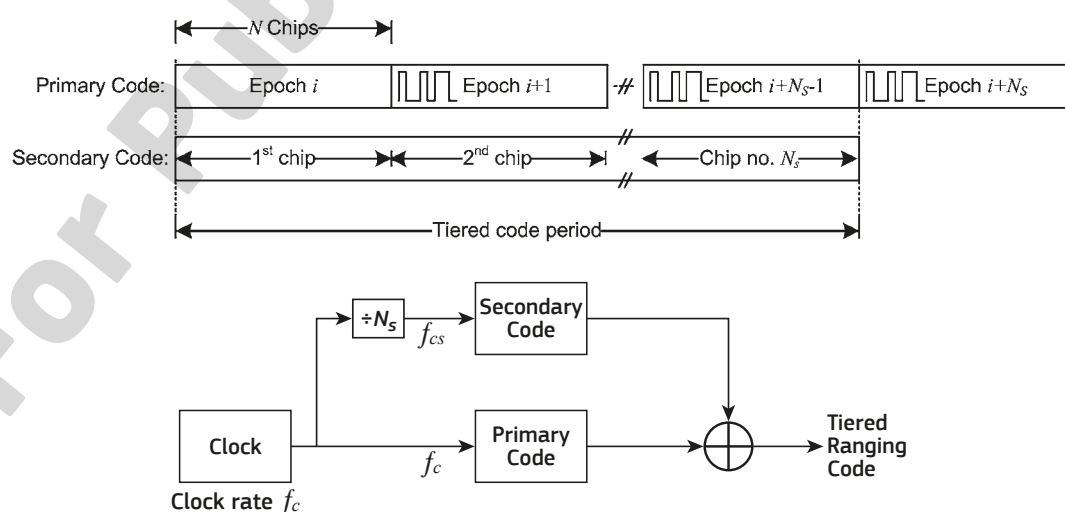

Figure 9. Tiered Codes Generation



### 3.3. Primary Codes Generation

The primary spreading codes can be either

- Linear feedback shift register-based pseudo-noise sequences, or
- Optimized pseudo-noise sequences

Optimized codes need to be stored in memory and therefore are often called ‘memory codes’. Register based codes used in Galileo are generated as combinations of two M-sequences, being truncated to the appropriate length. These codes can be generated either with pairs of LFSR or might be also stored in memory.

Figure 10 shows an example standard implementation of the LFSR method for the generation of truncated and combined M sequences. Two parallel shift registers are used: base register 1 and base register 2. The primary code output sequence is the exclusive OR of base register 1 and 2 output sequences, the shift between these two sequences is zero. Each shift register  $i$  ( $i=1$  for base register 1 and  $i = 2$  base register 2) of length  $R$  is fed back with a particular set of feedback taps  $\{a_{ij}\}_{j=1\dots R} = [a_{i,1}, a_{i,2}, \dots, a_{i,R}]$  and its content is represented by a vector  $\{c_{ij}\}_{j=1\dots R} = [c_{i,1}, c_{i,2}, \dots, c_{i,R}]$ . For truncation to primary code length  $N$ , the content of the two shift registers is reinitialised (reset) after  $N$  cycles with the so-called start-values  $\{s_{ij}\}_{j=1\dots R} = [s_{i,1}, s_{i,2}, \dots, s_{i,R}]$ .

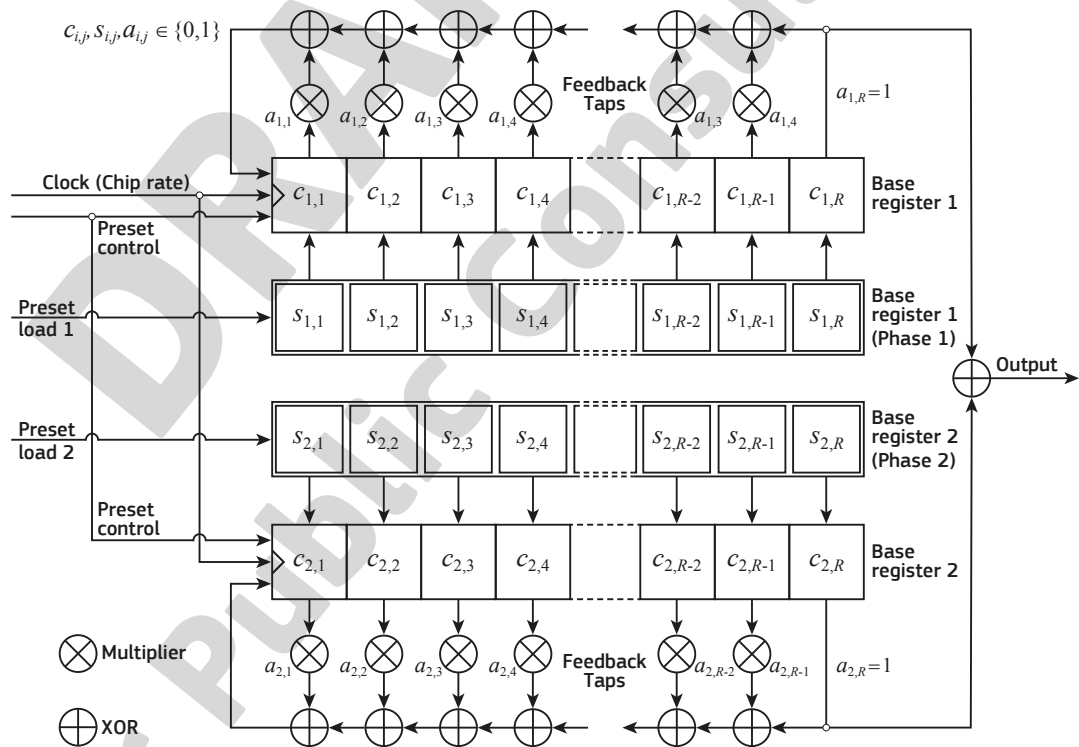

Figure 10. LFSR Based Code Generator for Truncated and Combined M-sequences

### 3.4. Primary Codes Definition

#### 3.4.1. E5 Primary Codes

The E5a-I, E5a-Q, E5b-I and E5b-Q primary codes are generated via LFSR, using the principle defined in paragraph 3.3, and the parameters defined in Table 14. Note that each set of codes for each signal component comprises 50 members.

Component	Shift Register Length (polynomial order)	Feedback Taps (octal)	
		Register 1	Register 2
E5a-I	14	40503	50661
E5a-Q	14	40503	50661
E5b-I	14	64021	51445
E5b-Q	14	64021	43143

Table 14. E5 Primary Codes Specifications

The transformation between the octal notation and the vector description  $\{a_{i,j}\}$  for the feedback tap positions is defined as follows and is illustrated with an example (Register 1 for E5a-I in Table 14) in Figure 11. After transferring the octal vector notation into binary notation, the bits are counted right to left starting with  $j = 0$  from the LSB and ending with  $j = R$  at the MSB, where  $R$  is the code register length. Then the  $j^{\text{th}}$  bit applies for the feedback tap  $a_{i,j}$  for  $j = 1, \dots, R$ , as shown in Figure 10. Note:  $a_{i,R}$  is always one and  $a_{i,0}$  is not considered in the register feedback tap.

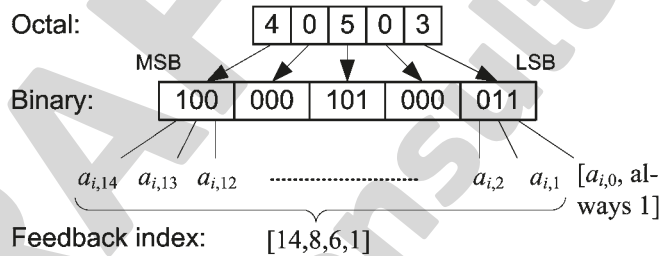

Figure 11. Code Register Feedback Taps Representation (example for E5a-I)

The start values for all base register 1 cells, in logic level notation, are '1' for all codes of E5a-I, E5a-Q, E5b-I and E5b-Q. The start values of base register 2 are provided in the subsequent sections. The transformation between the octal notation and the vector description  $\{s_{i,j}\}$  for the register start values is defined as follows and is illustrated with an example in Figure 12 (code number 1 of E5a-I in Table 15). After transferring the octal notation in binary notation, the bits are counted right to left starting with  $j=1$  (Note: the different start value compared to the feedback taps definition) from the LSB and ending with  $j=R$  at the MSB, where  $R$  is the code register length. Then the  $j^{\text{th}}$  bit applies to the start value  $s_{i,j}$  for  $j = 1, \dots, R$ , as shown in Figure 10. Note: in this example the MSB is zero in order to complete the 14-bits binary value sequence to fit into a sequence of octal symbols.

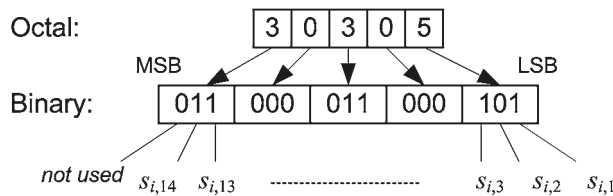

Figure 12. Start Value Representation for Base Register 2 (first code of E5a-I)

### 3.4.1.1. Base Register 2 Start Value for E5a-I

The octal format base register 2 start value with the convention defined in paragraph 3.4.1 is as defined in Table 15 for each primary E5a-I code. In addition, the conventional hexadecimal format of the first 24 code chips of the E5a-I primary codes is given in the table. For example, the first 24 chips of the E5a-I primary code N°1 in Table 15 are 0 0 1 1 1 1 0 0 1 1 1 0 1 0 1 0 1 0 1 1 1 0 1, the first binary value corresponding to the first primary code chip in time.

Code No	Start Value	Initial Sequence	Code No	Start Value	Initial Sequence
1	30305	3CEA9D	26	14401	9BFAC7
2	14234	9D8CF1	27	34727	18A25B
3	27213	45D1C8	28	22627	69A39F
4	20577	7A0133	29	30623	39B27D
5	23312	64D423	30	27256	454598
6	33463	23300D	31	01520	F2BC62
7	15614	91CEF2	32	14211	9DDBC6
8	12537	AA82DC	33	31465	332827
9	01527	F2A17D	34	22164	6E2FCA
10	30236	3D84AE	35	33516	22C6D5
11	27344	446D38	36	02737	E881D9
12	07272	C514F2	37	21316	74C4DB
13	36377	0C0184	38	35425	13AB03
14	17046	8767E0	39	35633	119323
15	06434	CB8EFF	40	24655	594886
16	15405	93EBCD	41	14054	9F4D89
17	24252	5D55CE	42	27027	47A3C0
18	11631	B19B7C	43	06604	C9ED53
19	24776	5805FC	44	31455	334994
20	00630	F99EA1	45	34465	1B2A30
21	11560	B23CE5	46	25273	5513F3
22	17272	8515E8	47	20763	7831C1
23	27445	436822	48	31721	30B93A
24	31702	30F77B	49	17312	84D5B4
25	13012	A7D629	50	13277	A5029C

Table 15. Base Register 2 Start Values and First Code Chip for E5a-I

### 3.4.1.2. Base Register 2 Start Value for E5a-Q

The octal format base register 2 start value with the convention defined in paragraph 3.4.1 is as defined in Table 16 for each E5a-Q primary code. The hexadecimal format of the first 24 code chips with the convention defined in paragraph 3.4.1.1 is also given.

Code No	Start Value	Initial Sequence	Code No	Start Value	Initial Sequence
1	25652	515537	26	20606	79E450
2	05142	D67539	27	11162	B63460
3	24723	58B2E5	28	22252	6D562B
4	31751	305914	29	30533	3A9010
5	27366	442710	30	24614	59CD72
6	24660	593CF8	31	07767	C0211A

Code No	Start Value	Initial Sequence	Code No	Start Value	Initial Sequence
7	33655	214AD7	32	32705	28EB96
8	27450	435EA6	33	05052	D7554B
9	07626	C1A7D5	34	27553	425126
10	01705	F0E94A	35	03711	E0DAFB
11	12717	A8C239	36	02041	EF79F2
12	32122	2EB63B	37	34775	18085D
13	16075	8F0A46	38	05274	D50CD8
14	16644	896DD4	39	37356	0447B9
15	37556	0245F1	40	16205	8DE877
16	02477	EB0160	41	36270	0D1FA0
17	02265	ED28B3	42	06600	C9FCF7
18	06430	CB9F5B	43	26773	48116D
19	25046	576592	44	17375	840BCC
20	12735	A88811	45	35267	152004
21	04262	DD3649	46	36255	0D4897
22	11230	B59F42	47	12044	AF6D25
23	00037	FF81F6	48	26442	4B7593
24	06137	CE8128	49	21621	71BB1B
25	04312	DCD55C	50	25411	53DA0E

Table 16. Base Register 2 start Values and First Code Chip for E5a-Q

### 3.4.1.3. Base Register 2 Start Value for E5b-I

The octal format base register 2 start value with the conventions defined in paragraph 3.4.1 is as defined in Table 17 for each E5b-I primary code. The hexadecimal format of the first 24 code chips with the conventions defined in paragraph 3.4.1.1 is also given.

Code No	Start Value	Initial Sequence	Code No	Start Value	Initial Sequence
1	07220	C5BEA1	26	25664	512FA9
2	26047	4F6248	27	21403	73F36B
3	00252	FD5488	28	32253	2D5317
4	17166	86277B	29	02337	EC8390
5	14161	9E39D5	30	30777	380374
6	02540	EA7EDE	31	27122	46B4DE
7	01537	F28321	32	22377	6C01D9
8	26023	4FB0C9	33	36175	0E0BB6
9	01725	FOAB64	34	33075	2708C7
10	20637	79833B	35	33151	265B55
11	02364	EC2D91	36	13134	A68E1C

Code No	Start Value	Initial Sequence	Code No	Start Value	Initial Sequence
12	27731	409B11	37	07433	C3916E
13	30640	397E16	38	10216	BDC595
14	34174	1E0FCD	39	35466	1327D0
15	06464	CB2F5A	40	02533	EA921F
16	07676	C1079A	41	05351	D45869
17	32231	2D9BC6	42	30121	3EB98A
18	10353	BC5146	43	14010	9FDE16
19	00755	F848B0	44	32576	2A04CA
20	26077	4F01E8	45	30326	3CA56F
21	11644	B16C9B	46	37433	03928A
22	11537	B2827D	47	26022	4FB5B9
23	35115	16C809	48	35770	101EC7
24	20452	7B570F	49	06670	C91D4F
25	34645	1969C0	50	12017	AFC22B

Table 17. Base Register 2 Start Values and First Code Chip for E5b-l

#### 3.4.1.4. Base Register 2 Start Value for E5b-Q

The octal format base register 2 start value with the conventions defined in paragraph 3.4.1 is as defined in Table 18 for each E5b-Q primary code. The hexadecimal format of the first 24 code chips with the conventions defined in paragraph 3.4.1.1 is also given.

Code No	Start Value	Initial Sequence	Code No	Start Value	Initial Sequence
1	03331	E49AF0	26	20134	7E8CFB
2	06143	CE701F	27	11262	B536C3
3	25322	54B709	28	10706	B8E68C
4	23371	641AB1	29	34143	1E7272
5	00413	FBD0AE	30	11051	B75B69
6	36235	0D8BC9	31	25460	533F65
7	17750	805FA5	32	17665	812B41
8	04745	D86BA0	33	32354	2C4DE1
9	13005	A7E921	34	21230	759E2C
10	37140	067E55	35	20146	7E6434
11	30155	3E4B58	36	11362	B43640
12	20237	7D82FB	37	37246	05671B
13	03461	E33BC2	38	16344	8C6FE0
14	31662	31372C	39	15034	978D4E
15	27146	46676F	40	25471	5319BF
16	05547	D2613E	41	25646	516499

Code No	Start Value	Initial Sequence	Code No	Start Value	Initial Sequence
17	02456	EB443C	42	22157	6E4292
18	30013	3FD0B1	43	04336	DC86A3
19	00322	FCB7CF	44	16356	8C46BE
20	10761	B83815	45	04075	DF0B03
21	26767	48224A	46	02626	E9A5B2
22	36004	0FEE25	47	11706	BOE553
23	30713	38D33B	48	37011	07DBAC
24	07662	C135B9	49	27041	4778E4
25	21610	71DE13	50	31024	37AF4F

Table 18. Base Register 2 Start Values and First Code Chip for E5b-Q

### 3.4.2. E1-B and E1-C Primary Codes

The E1-B and E1-C primary codes are pseudo-random memory code sequences according to the hexadecimal representation provided in Annex C (provided only in the electronic version of this ICD). Note that each set of codes for each signal component comprises 50 members.

## 3.5. Secondary Codes

### 3.5.1. Definition of Secondary Codes

The secondary codes are fixed sequences as defined in hexadecimal notation in Table 19 and Table 20, following again the convention used in paragraph 3.4.1.1. For secondary codes whose length is not divisible by four (case of CS25<sub>1</sub> only), the last (most right-hand) hexadecimal symbol is obtained by filling up the last group of code chips with zeros at the end in time (to the right), to reach a final length of 4 binary symbols. Those two tables provide as well the code identifiers together with the code lengths, the number of hexadecimal symbols and the number of filled zeros.

For example, the CS25<sub>1</sub> secondary code in Table 19 corresponds to the binary sequence '0 0 1 1 1 0 0 0 0 0 0 1 0 1 0 1 1 0 1 1 0 0 1 0', the first binary value corresponding to the first secondary code chip in time.

Code Identifier	Code Length	No. of Hexadec. Symbols	Number of Filled up Zeros	Code Sequence
CS4 <sub>1</sub>	4	1	0	E
CS20 <sub>1</sub>	20	5	0	842E9
CS25 <sub>1</sub>	25	7	3	380AD90
CS100 <sub>1</sub>	100	25	0	83F6F69D8F6E15411FB8C9B1C
CS100 <sub>2</sub>	100	25	0	66558BD3CE0C7792E83350525
CS100 <sub>3</sub>	100	25	0	59A025A9C1AF0651B779A8381
CS100 <sub>4</sub>	100	25	0	D3A32640782F7B18E4DF754B7
CS100 <sub>5</sub>	100	25	0	B91FCAD7760C218FA59348A93
CS100 <sub>6</sub>	100	25	0	BAC77E933A779140F094FBF98

Code Identifier	Code Length	No. of Hexadec. Symbols	Number of Filled up Zeros	Code Sequence
CS100 <sub>7</sub>	100	25	0	537785DE280927C6B58BA6776
CS100 <sub>8</sub>	100	25	0	EFCAB4B65F38531ECA22257E2
CS100 <sub>9</sub>	100	25	0	79F8CAE838475EA5584BEFC9B
CS100 <sub>10</sub>	100	25	0	CA5170FEA3A810EC606B66494
CS100 <sub>11</sub>	100	25	0	1FC32410652A2C49BD845E567
CS100 <sub>12</sub>	100	25	0	FE0A9A7AFDAC44E42CB95D261
CS100 <sub>13</sub>	100	25	0	B03062DC2B71995D5AD8B7DBE
CS100 <sub>14</sub>	100	25	0	F6C398993F598E2DF4235D3D5
CS100 <sub>15</sub>	100	25	0	1BB2FB8B5BF24395C2EF3C5A1
CS100 <sub>16</sub>	100	25	0	2F920687D238CC7046EF6AFC9
CS100 <sub>17</sub>	100	25	0	34163886FC4ED7F2A92EFDBB8
CS100 <sub>18</sub>	100	25	0	66A872CE47833FB2DFD5625AD
CS100 <sub>19</sub>	100	25	0	99D5A70162C920A4BB9DE1CA8
CS100 <sub>20</sub>	100	25	0	81D71BD6E069A7ACCBEDC66CA
CS100 <sub>21</sub>	100	25	0	A654524074A9E6780DB9D3EC6
CS100 <sub>22</sub>	100	25	0	C3396A101BEDAF623CFC5BB37
CS100 <sub>23</sub>	100	25	0	C3D4AB211DF36F2111F2141CD
CS100 <sub>24</sub>	100	25	0	3DFF25EAE761739265AF145C1
CS100 <sub>25</sub>	100	25	0	994909E0757D70CDE389102B5
CS100 <sub>26</sub>	100	25	0	B938535522D119F40C25FDAEC
CS100 <sub>27</sub>	100	25	0	C71AB549C0491537026B390B7
CS100 <sub>28</sub>	100	25	0	0CDB8C9E7B53F55F5B0A0597B
CS100 <sub>29</sub>	100	25	0	61C5FA252F1AF81144766494F
CS100 <sub>30</sub>	100	25	0	626027778FD3C6BB4BAA7A59D
CS100 <sub>31</sub>	100	25	0	E745412FF53DEBD03F1C9A633
CS100 <sub>32</sub>	100	25	0	3592AC083F3175FA724639098
CS100 <sub>33</sub>	100	25	0	52284D941C3DCAF2721DDB1FD
CS100 <sub>34</sub>	100	25	0	73B3D8F0AD55DF4FE814ED890
CS100 <sub>35</sub>	100	25	0	94BF16C83BD7462F6498E0282
CS100 <sub>36</sub>	100	25	0	A8C3DE1AC668089B0B45B3579
CS100 <sub>37</sub>	100	25	0	E23FFC2DD2C14388AD8D6BEC8
CS100 <sub>38</sub>	100	25	0	F2AC871CDF89DDC06B5960D2B
CS100 <sub>39</sub>	100	25	0	06191EC1F622A77A526868BA1
CS100 <sub>40</sub>	100	25	0	22D6E2A768E5F35FFC8E01796
CS100 <sub>41</sub>	100	25	0	25310A06675EB271F2A09EA1D
CS100 <sub>42</sub>	100	25	0	9F7993C621D4BEC81A0535703
CS100 <sub>43</sub>	100	25	0	D62999EACF1C99083C0B4A417

Code Identifier	Code Length	No. of Hexadec. Symbols	Number of Filled up Zeros	Code Sequence
CS100 <sub>44</sub>	100	25	0	F665A7EA441BAA4EA0D01078C
CS100 <sub>45</sub>	100	25	0	46F3D3043F24CDEABD6F79543
CS100 <sub>46</sub>	100	25	0	E2E3E8254616BD96CEFCA651A
CS100 <sub>47</sub>	100	25	0	E548231A82F9A01A19DB5E1B2
CS100 <sub>48</sub>	100	25	0	265C7F90A16F49EDE2AA706C8
CS100 <sub>49</sub>	100	25	0	364A3A9EB0F0481DA0199D7EA
CS100 <sub>50</sub>	100	25	0	9810A7A898961263A0F749F56

Table 19. Secondary Code Sequences (Part 1)

Code Identifier	Code Length	No. of Hexadec. Symbols	Number of Filled up Zeros	Code Sequence
CS100 <sub>51</sub>	100	25	0	CFF914EE3C6126A49FD5E5C94
CS100 <sub>52</sub>	100	25	0	FC317C9A9BF8C6038B5CADAB3
CS100 <sub>53</sub>	100	25	0	A2EAD74B6F9866E414393F239
CS100 <sub>54</sub>	100	25	0	72F2B1180FA6B802CB84DF997
CS100 <sub>55</sub>	100	25	0	13E3AE93BC52391D09E84A982
CS100 <sub>56</sub>	100	25	0	77C04202B91B22C6D3469768E
CS100 <sub>57</sub>	100	25	0	FEBC592DD7C69AB103D0BB29C
CS100 <sub>58</sub>	100	25	0	0B494077E7C66FB6C51942A77
CS100 <sub>59</sub>	100	25	0	DD0E321837A3D52169B7B577C
CS100 <sub>60</sub>	100	25	0	43DEA90EA6C483E7990C3223F
CS100 <sub>61</sub>	100	25	0	0366AB33F0167B6FA979DAE18
CS100 <sub>62</sub>	100	25	0	99CCBBFAB1242CBE31E1BD52D
CS100 <sub>63</sub>	100	25	0	A3466923CEFD451EC0FCED22
CS100 <sub>64</sub>	100	25	0	1A5271F22A6F9A8D76E79B7F0
CS100 <sub>65</sub>	100	25	0	3204A6BB91B49D1A2D3857960
CS100 <sub>66</sub>	100	25	0	32F83ADD43B599CBFB8628E5B
CS100 <sub>67</sub>	100	25	0	3871FB0D89DB77553EB613CC1
CS100 <sub>68</sub>	100	25	0	6A3CBDFF2D64D17E02773C645
CS100 <sub>69</sub>	100	25	0	2BCD09889A1D7FC219F2EDE3B
CS100 <sub>70</sub>	100	25	0	3E49467F4D4280B9942CD6F8C
CS100 <sub>71</sub>	100	25	0	658E336DCFD9809F86D54A501
CS100 <sub>72</sub>	100	25	0	ED4284F345170CF77268C8584
CS100 <sub>73</sub>	100	25	0	29ECCE910D832CAF15E3DF5D1
CS100 <sub>74</sub>	100	25	0	456CCF7FE9353D50E87A708FA
CS100 <sub>75</sub>	100	25	0	FB757CC9E18CBC02BF1B84B9A
CS100 <sub>76</sub>	100	25	0	5686229A8D98224BC426BC7FC



Code Identifier	Code Length	No. of Hexadec. Symbols	Number of Filled up Zeros	Code Sequence
CS100 <sub>77</sub>	100	25	0	700A2D325EA14C4B7B7AA8338
CS100 <sub>78</sub>	100	25	0	1210A330B4D3B507D854CBA3F
CS100 <sub>79</sub>	100	25	0	438EE410BD2F7DBCDD85565BA
CS100 <sub>80</sub>	100	25	0	4B9764CC455AE1F61F7DA432B
CS100 <sub>81</sub>	100	25	0	BF1F45FDDA3594ACF3C4CC806
CS100 <sub>82</sub>	100	25	0	DA425440FE8F6E2C11B8EC1A4
CS100 <sub>83</sub>	100	25	0	EE2C8057A7C16999AFA33FED1
CS100 <sub>84</sub>	100	25	0	2C8BD7D8395C61DFA96243491
CS100 <sub>85</sub>	100	25	0	391E4BB6BC43E98150CDDCADA
CS100 <sub>86</sub>	100	25	0	399F72A9EADB42C90C3ECF7F0
CS100 <sub>87</sub>	100	25	0	93031FDEA588F88E83951270C
CS100 <sub>88</sub>	100	25	0	BA8061462D873705E95D5CB37
CS100 <sub>89</sub>	100	25	0	D24188F88544EB121E963FD34
CS100 <sub>90</sub>	100	25	0	D5F6A8BB081D8F383825A4DCA
CS100 <sub>91</sub>	100	25	0	0FA4A205F0D76088D08EAF267
CS100 <sub>92</sub>	100	25	0	272E909FAEBC65215E263E258
CS100 <sub>93</sub>	100	25	0	3370F35A674922828465FC816
CS100 <sub>94</sub>	100	25	0	54EF96116D4A0C8DB0E07101F
CS100 <sub>95</sub>	100	25	0	DE347C7B27FADC48EF1826A2B
CS100 <sub>96</sub>	100	25	0	01B16ECA6FC343AE08C5B8944
CS100 <sub>97</sub>	100	25	0	1854DB743500EE94D8FC768ED
CS100 <sub>98</sub>	100	25	0	28E40C684C87370CD0597FAB4
CS100 <sub>99</sub>	100	25	0	5E42C19717093353BCAAF4033
CS100 <sub>100</sub>	100	25	0	64310BAD8EB5B36E38646AF01

Table 20. Secondary Code Sequences (Part 2)

### 3.5.2. Secondary Codes Assignment

The assignment of the secondary codes of paragraph 3.5.1 to the signal components is according to Table 21. For the 4, 20 and 25 bit secondary codes the same code is used for all associated primary codes. For the 100 bit codes, an independent secondary code is assigned for each primary code.

Component	Secondary Code Assignment
E5a-I	CS20 <sub>1</sub>
E5a-Q	CS100 <sub>1-50</sub>
E5b-I	CS4 <sub>1</sub>
E5b-Q	CS100 <sub>51-100</sub>
E6-B	N/A

Component	Secondary Code Assignment
E6-C	CS100 <sub>1-50</sub>
E1-B	N/A
E1-C	CS25 <sub>1</sub>

Table 21. Secondary Code Assignment

### 3.6. Code Assignments to Satellites

#### 3.6.1. Primary code assignment to satellites

The E5a-I, E5a-Q, E5b-I, E5b-Q, primary codes (defined in Section 3.4.1) and E1-B, E1-C primary codes (defined in Annex C of the electronic version of this ICD) will be allocated to the space vehicle IDs (SVID) as follows:

- To SVID  $n$  (with  $n = 1$  to  $36$ ) are assigned the corresponding E5a-I, E5a-Q, E5b-I, E5b-Q, E1-B and E1-C primary code number  $n$ .

#### 3.6.2. Secondary code assignment to satellites

The E5a-I, E5a-Q, E5b-I, E5b-Q, and E1-C secondary codes (defined in Section 3.5.1) are allocated to the space vehicle IDs (SVID) as follows:

- The following secondary codes are assigned according to SVID  $n$  (with  $n = 1$  to  $36$ ):
  - secondary code CS100 <sub>$n$</sub>  for the signal component E5a-Q (i.e. CS100<sub>1</sub> to SVID 1)
  - secondary code CS100<sub>( $n+50$ )</sub> for the signal component E5b-Q (i.e. CS100<sub>51</sub> to SVID 1)
- The following secondary codes are assigned to all SVIDs (1 to 36):
  - secondary code CS20<sub>1</sub> for the signal component E5a-I (same for all SVIDs)
  - secondary code CS4<sub>1</sub> for the signal component E5b-I (same for all SVIDs)
  - secondary code CS25<sub>1</sub> for the signal component E1-C (same for all SVIDs)

## 4. Galileo Message Structure

### 4.1. General Message Format Specification

#### 4.1.1. General Navigation Message Content

The Galileo signal-in-space data channels transmit different message types according to the general contents identified in Table 22 below. The F/NAV types of message correspond to the OS and the I/NAV types of message correspond to both OS and CS.

Message Type	Services	Component
F/NAV	OS	E5a-I
I/NAV	OS/CS	E5b-I and E1-B
C/NAV	CS	E6-B

Table 22. Message Allocation and General Data Content

Note: The C/NAV message format is not the subject of this SIS ICD.

#### 4.1.2. General Navigation Message Structure

The complete navigation message data are transmitted on each data component as a sequence of frames. A frame is composed of several sub-frames, and a sub-frame in turn is composed of several pages. The page is the basic structure for building the navigation message.

For all message types, only the message pages include a 'type' marker to identify the content of each page received by the user. There is no management data transmitted within the navigation message to indicate subframe and frame structures, and indeed these higher level structures should be considered as the typical flow of pages reflecting the current Galileo navigation message design, which may evolve together with future evolutions of Galileo. This evolution may also involve the inclusion of additional new page types beyond the types defined in this version of the Galileo OS SIS ICD. A user receiver is expected to be able to recognize page types and to react properly and in a well controlled manner to page types unknown to its software as well as to variations in the order of received pages.

#### 4.1.3. Bit and Byte Ordering Criteria

All data values are encoded using the following bit and byte ordering criteria:

- For numbering, the most significant bit/byte is numbered as bit/byte 0
- For bit/byte ordering, the most significant bit/byte is transmitted first

#### 4.1.4. FEC Coding and Interleaving Parameters

##### 4.1.4.1. FEC Encoding

The convolutional encoding for all data pages on all signal components is performed according to the parameters given in Table 23.

Code Parameter	Value
Coding Rate	$\frac{1}{2}$
Coding Scheme	Convolutional
Constraint Length	7
Generator Polynomials	$G1=1710$ $G2=1330$
Encoding Sequence	$G1$ then $G2$

Table 23. Data Coding Parameters

Figure 13 depicts this convolutional coding scheme. Decoding can be implemented using a standard Viterbi decoder.

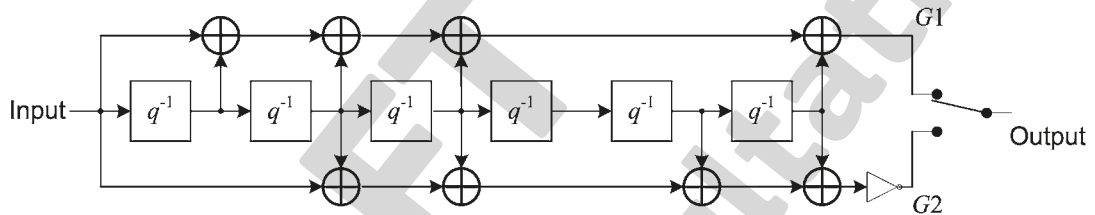

Figure 13. Convolutional Coding Scheme

Note: Figure 13 describes an encoder where the second branch is inverted at the end.

#### 4.1.4.2. Interleaving

For each message type, the FEC encoded page is interleaved using a block interleaver with  $n$  columns (where data is written) and  $k$  rows (where data is read), as shown in Table 24.

Parameters	Message Type	
	F/NAV	I/NAV
Block interleaver size (Symbols)	488	240
Block interleaver dimensions ( $n$ columns x $k$ rows)	61 x 8	30 x 8

Table 24. Interleaving Parameters

#### 4.1.5. Frame and Page Timing

Time stamps are inserted in the navigation message at regular intervals by the broadcasting satellite to identify absolute Galileo System Time (GST). The exact timing of the page frame boundaries is used to identify fractional GST timing (less than one frame period). This is measured relative to the leading edge of the first chip of the first code sequence of the first page symbol of the page containing the TOW. The transmission timing of the navigation message provided through the TOW is synchronised to each satellite's version of GST.

## 4.2. F/NAV Message Description

### 4.2.1. General Description of the F/NAV Message

The F/NAV message structure is presented in Figure 14, where the duration of each entity is indicated.

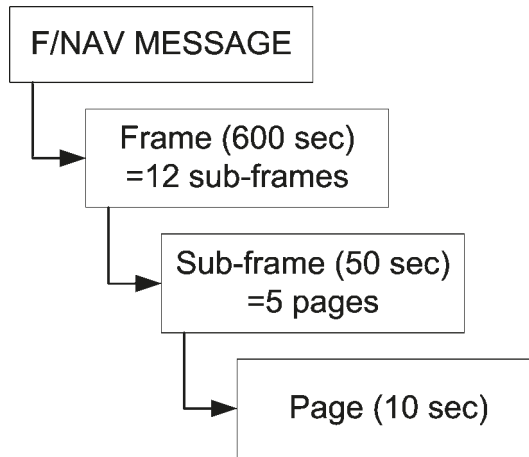

Figure 14. F/NAV Message Structure

#### 4.2.2. F/NAV Page Layout

The page layout for the F/NAV message type is according to Table 25 where the symbols allocation and bits allocation are shown separately. The different fields composing this layout are defined in the sections below.

Sync.	F/NAV Symbols			Total (symb)
12	488			500

F/NAV Word			Tail	Total (bits)
Page type	Navigation Data	CRC		
6	208	24	6	244

Table 25. F/NAV Page Layout

##### 4.2.2.1. Synchronisation Pattern

The synchronization pattern allows the receiver to achieve synchronisation to the page boundary.

Note: The synchronisation pattern is not encoded. The F/NAV synchronisation pattern is 101101110000

##### 4.2.2.2. Tail Bits

The tail bits field consists of 6 zero-value bits enabling completion of the FEC decoding of each page's information content in the user receiver.

##### 4.2.2.3. F/NAV Word

The useful data are contained in the F/NAV word composed of

- A page type field (6 bits) enabling to identify the page content as defined in paragraph 4.2.4
- A navigation data field (208 bits) whose structure is presented in paragraph 4.2.4
- A CRC (24 bits) to detect potential bit errors, according to paragraph 5.1.9.4. The CRC is computed on the Page Type and Navigation Data fields.

#### 4.2.3. F/NAV Frame Layout

The F/NAV E5a-I message data packet transmission sequence is according to Table 26 where a whole frame is shown. Note that the odd numbered sub-frames contain the

page type 5 and the even numbered sub-frames contain the page type 6. This allows the transmission of the almanacs for three satellites within two successive sub-frames (100 seconds). The parameter  $k$  is transparent for the user. It is set by the Galileo system for each of the active satellites, such as to improve almanac transport time by exploiting source diversity.

	Page Type	Page Content
<b>Subframe 1</b>	1	SVID, clock correction, SISA, Ionospheric correction, BGD, Signal health status, GST and Data validity status
	2	Ephemeris (1/3) and GST
	3	Ephemeris (2/3) and GST
	4	Ephemeris (3/3), GST-UTC conversion, GST-GPS Conversion and TOW
	5	Almanac for satellite $k$ and almanac for satellite $(k+1)$ part 1
<b>Subframe 2</b>	1	SVID, clock correction, SISA, Ionospheric correction, BGD, Signal health status, GST and Data validity status
	2	Ephemeris (1/3) and GST
	3	Ephemeris (2/3) and GST
	4	Ephemeris (3/3), GST-UTC conversion, GST-GPS Conversion and TOW
	6	Almanac for satellite $(k+1)$ part 2 and almanac for satellite $(k+2)$
<b>Subframe 3</b>	1	SVID, clock correction, SISA, Ionospheric correction, BGD, Signal health status, GST and Data validity status
	2	Ephemeris (1/3) and GST
	3	Ephemeris (2/3) and GST
	4	Ephemeris (3/3), GST-UTC conversion, GST-GPS Conversion and TOW
	5	Almanac for satellite $(k+3)$ and almanac for satellite $(k+4)$ part 1
<b>Subframe 4</b>	1	SVID, clock correction, SISA, Ionospheric correction, BGD, Signal health status, GST and Data validity status
	2	Ephemeris (1/3) and GST
	3	Ephemeris (2/3) and GST
	4	Ephemeris (3/3), GST-UTC conversion, GST-GPS Conversion and TOW
	6	Almanac for satellite $(k+4)$ part 2 and almanac for satellite $(k+5)$
<b>Subframe 5</b>	1	SVID, clock correction, SISA, Ionospheric correction, BGD, Signal health status, GST and Data validity status
	2	Ephemeris (1/3) and GST
	3	Ephemeris (2/3) and GST
	4	Ephemeris (3/3), GST-UTC conversion, GST-GPS Conversion and TOW
	5	Almanac for satellite $(k+6)$ and almanac for satellite $(k+7)$ part 1
<b>Subframe 6</b>	1	SVID, clock correction, SISA, Ionospheric correction, BGD, Signal health status, GST and Data validity status
	2	Ephemeris (1/3) and GST
	3	Ephemeris (2/3) and GST
	4	Ephemeris (3/3), GST-UTC conversion, GST-GPS Conversion and TOW
	6	Almanac for satellite $(k+7)$ part 2 and almanac for satellite $(k+8)$

	Page Type	Page Content
<b>Subframe 7</b>	1	SVID, clock correction, SISA, Ionospheric correction, BGD, Signal health status, GST and Data validity status
	2	Ephemeris (1/3) and GST
	3	Ephemeris (2/3) and GST
	4	Ephemeris (3/3), GST-UTC conversion, GST-GPS Conversion and TOW
	5	Almanac for satellite (k+9) and almanac for satellite (k+10) part 1
<b>Subframe 8</b>	1	SVID, clock correction, SISA, Ionospheric correction, BGD, Signal health status, GST and Data validity status
	2	Ephemeris (1/3) and GST
	3	Ephemeris (2/3) and GST
	4	Ephemeris (3/3), GST-UTC conversion, GST-GPS Conversion and TOW
	6	Almanac for satellite (k+10) part 2 and almanac for satellite (k+11)
<b>Subframe 9</b>	1	SVID, clock correction, SISA, Ionospheric correction, BGD, Signal health status, GST and Data validity status
	2	Ephemeris (1/3) and GST
	3	Ephemeris (2/3) and GST
	4	Ephemeris (3/3), GST-UTC conversion, GST-GPS Conversion and TOW
	5	Almanac for satellite (k+12) and almanac for satellite (k+13) part 1
<b>Subframe 10</b>	1	SVID, clock correction, SISA, Ionospheric correction, BGD, Signal health status, GST and Data validity status
	2	Ephemeris (1/3) and GST
	3	Ephemeris (2/3) and GST
	4	Ephemeris (3/3), GST-UTC conversion, GST-GPS Conversion and TOW
	6	Almanac for satellite (k+13) part 2 and almanac for satellite (k+14)
<b>Subframe 11</b>	1	SVID, clock correction, SISA, Ionospheric correction, BGD, Signal health status, GST and Data validity status
	2	Ephemeris (1/3) and GST
	3	Ephemeris (2/3) and GST
	4	Ephemeris (3/3), GST-UTC conversion, GST-GPS Conversion and TOW
	5	Almanac for satellite (k+15) and almanac for satellite (k+16) part 1
<b>Subframe 12</b>	1	SVID, clock correction, SISA, Ionospheric correction, BGD, Signal health status, GST and Data validity status
	2	Ephemeris (1/3) and GST
	3	Ephemeris (2/3) and GST
	4	Ephemeris (3/3), GST-UTC conversion, GST-GPS Conversion and TOW
	6	Almanac for satellite (k+16) part 2 and almanac for satellite (k+17)

Table 26. F/NAV Frame Layout

#### 4.2.4. F/NAV Page Contents

The following tables specify the contents of the F/NAV pages above allocated (see Chapter 5 for a description of the F/NAV pages contents).

Page Type 1: SVID, Clock correction, SISA, Ionospheric correction, BGD, GST, Signal health and Data validity status

Type=1	SVID	IOD <sub>nav</sub>	Clock correction				SISA(E1,E5a)	Ionospheric correction					BGD(E1,E5a)	E5a <sub>HS</sub>	GST		E5a <sub>SV5</sub>	Spare	CRC	Tail	Total (bits)			
			t <sub>oc</sub>	a <sub>f0</sub>	a <sub>f1</sub>	a <sub>f2</sub>		Az			Ionospheric disturbance flag				WN	TOW								
								a <sub>i0</sub>	a <sub>i1</sub>	a <sub>i2</sub>	Region 1	Region 2										Region 3	Region 4	Region 5
6	6	10	14	31	21	6	8	11	11	14	1	1	1	1	1	10	2	12	20	1	26	24	6	244

Table 27. Bits Allocation for F/NAV Page Type 1

Page Type 2: Ephemeris (1/3) and GST

Type=2	IOD <sub>nav</sub>	Ephemeris (1/3)						GST		CRC	Tail	Total (bits)	
		M <sub>0</sub>	•Ω	e	A <sub>1/2</sub>	Ω <sub>0</sub>	•i	WN	TOW				
6	10	32	24	32	32	32	32	14	12	20	24	6	244

Table 28. Bits Allocation for F/NAV Page Type 2

Page Type 3: Ephemeris (2/3) and GST

Type=3	IOD <sub>nav</sub>	Ephemeris (2/3)							GST		Spare	CRC	Tail	Total (bits)		
		i <sub>0</sub>	ω	Δn	C <sub>ic</sub>	C <sub>is</sub>	C <sub>rc</sub>	C <sub>rs</sub>	t <sub>oe</sub>	WN					TOW	
6	10	32	32	16	16	16	16	16	16	14	12	20	8	24	6	244

Table 29. Bits Allocation for F/NAV Page Type 3

Page Type 4: Ephemeris (3/3), GST-UTC conversion, GST-GPS conversion and TOW.

Type=4	IOD <sub>nav</sub>	Ephemeris (3/3)		GST-UTC Conversion						GST-GPS Conversion				TOW	Spare	CRC	Tail	Total (bits)		
		C <sub>ic</sub>	C <sub>is</sub>	A <sub>0</sub>	A <sub>1</sub>	ΔL <sub>s</sub>	t <sub>ot</sub>	WN <sub>ot</sub>	WN <sub>LSF</sub>	DN	ΔL <sub>sF</sub>	t <sub>0G</sub>	A <sub>0G</sub>						A <sub>1G</sub>	WN <sub>0G</sub>
6	10	16	16	32	24	8	8	8	8	3	8	8	16	12	6	20	5	24	6	244

Table 30. Bits Allocation for F/NAV Page Type 4

Page Type 5: Almanac (SVID1 and SVID2(1/2)), Week Number and almanac reference time

Type=5	IOD <sub>a</sub>	WN <sub>a</sub>	t <sub>oa</sub>	SV <sub>SVID1</sub>								SV <sub>SVID2(1/2)</sub>				CRC	Tail	Total (bits)						
				SVID1	Δ(A <sub>1/2</sub> )	e	ω	δi	Ω <sub>0</sub>	•Ω	M <sub>0</sub>	a <sub>f0</sub>	a <sub>f1</sub>	E5a <sub>HS</sub>	SVID2				Δ(A <sub>1/2</sub> )	e	ω	δi	Ω <sub>0(1/2)</sub>	
6	4	2	10	6	13	11	16	11	16	11	16	16	16	13	2	6	13	11	16	11	4	24	6	244

Table 31. Bits Allocation for F/NAV Page Type 5



Page Type 6: Almanac (SVID2(2/2) and SVID3)

Type=6	IOD <sub>a</sub>	SV <sub>SVID2(2/2)</sub>						SV <sub>SVID3</sub>						Spare	CRC	Tail	Total (bits)					
		$\Omega_0$ (2/2)	$\dot{\Omega}$	$M_0$	$a_{f0}$	$a_{f1}$	E5aHS	SVID3	$\Delta(A/2)$	$e$	$\omega$	$\delta_i$	$\Omega_0$					$\dot{\Omega}$	$M_0$	$a_{f0}$	$a_{f1}$	E5aHS
6	4	12	11	16	16	13	2	6	13	11	16	11	16	11	16	16	13	2	3	24	6	244

Table 32. Bits Allocation for F/NAV Page Type 6

#### 4.2.5. F/NAV Dummy Page Definition

In case no valid F/NAV data is to be transmitted, the satellite generates and downlinks the dummy pages (Page Type 63) replacing the pages in the nominal sequencing, according to the format in Table 33. CRC is computed on the Page Type and Dummy sequence fields.

Type=63	Dummy sequence	CRC	Tail	Total (bits)
6	208	24	6	244

Table 33. Bits Allocation for F/NAV Dummy Page

### 4.3. I/NAV Message Description

#### 4.3.1. General Description of the I/NAV Message

The I/NAV message structure is presented in Figure 15, where the duration of each entity is indicated.

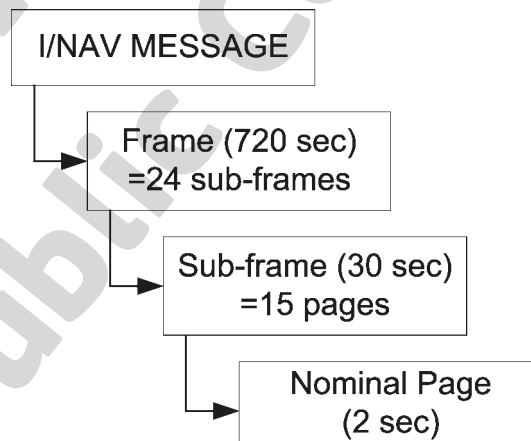

Figure 15. I/NAV Message Structure in the Nominal Mode

The I/NAV message structures for the E5b-I and E1-B signals use the same page layout since the service provided on these frequencies is a dual frequency service, using frequency diversity. Only page sequencing is different, with page swapping between both components in order to allow a fast reception of data by a dual frequency receiver. Nevertheless, the frame is designed to allow receivers to work also with a single frequency.

#### 4.3.2. I/NAV Page Layout

Two types of I/NAV pages are defined:

- Nominal pages having a duration of 2 seconds transmitted sequentially in time in two parts of duration 1 second each on each of the E5b-I and E1-B components according

to Table 35. The first part of a page is denoted 'even' and the second one is denoted 'odd'.

- Alert pages having a duration of 1 second transmitted in two parts of duration 1 second each at the same epoch over the E5b-I and E1-B components according to Table 35. Again, the first part of a page is denoted 'even' and the second one is denoted 'odd'. This transmission is repeated at the next epoch but switching the two parts between the components.

The I/NAV page part (even or odd) layout is defined in Table 34 for both nominal and alert page types. This table shows the symbols allocation and bits allocation separately. The different fields composing this layout are defined in the sections below.

Sync.	I/NAV Page Part (even or odd) Symbols	Total (symp)
10	240	250

I/NAV Page Part (even or odd) Bits	Tail	Total (bits)
114	6	120

Table 34. I/NAV Page Part Layout

#### 4.3.2.1. Synchronisation Pattern

The synchronization pattern allows the receiver to achieve synchronisation to the page boundary.

Note: The synchronisation pattern is not encoded. The I/NAV synchronisation pattern is 0101100000

#### 4.3.2.2. Tail Bits

The tail bits field consists of 6 zero-value bits enabling completion of the FEC decoding of each page's information content in the user receiver.

#### 4.3.2.3. I/NAV Page Part

The structure of the nominal I/NAV even and odd page parts on E5b-I and E1-B are defined in Table 35. A nominal page is composed by the two page parts (even and odd) transmitted sequentially over the same frequency ("vertical page").

E5b-I							E1-B											
Even/odd=0	Page Type	Data i (1/2)					Tail	Total (bits)	Even/odd=1	Page Type	Data j (2/2)	Reserved 1	SAR	Spare	CRC <sub>j</sub>	Reserved 2	Tail	Total (bits)
1	1	112					6		120	1	1	16	40	22	2	24	8	
Even/odd=1	Page Type	Data i (2/2)	Reserved 1	CRC <sub>i</sub>	Reserved 2	Tail	Total (bits)	Even/odd=0	Page Type	Data k (1/2)					Tail	Total (bits)		
1	1	16	64	24	8	6		120	1	1	112						6	120

Table 35. I/NAV Nominal Page with Bits Allocation

The parameters for the nominal page have the following meaning and related values:

- Even/Odd field (1 bit) to indicate the part of the page (0=even/1=odd) that is broadcast
- Page Type (1 bit) equal to 0 to indicate the nominal page type
- Data field composed of a nominal word (described in 4.3.5) of 128 bits (comprising 112 bits of data (1/2) and 16 bits of data (2/2))
- The reserved fields will be published in a future update of this ICD
- SAR data (22 bits) composed of SAR RLM data on E1-B only as defined in 4.3.7
- CRC (24 bits) computed on the Even/Odd fields, Page Type fields, Data fields (1/2 and 2/2), Spare field, SAR (on E1-B only) and reserved fields (Reserved 1 for E5b-I and Reserved 1 for E1-B). In nominal mode the CRC is computed for the Even and Odd parts of a page of the same frequency (“vertical CRC”) and is always broadcast on the second part of the “vertical page”.

Note: The Reserved 2 field on E5b-I and the Reserved 2 field on E1-B are not protected by the CRC.

- Tail bits (2\*6 bits) as defined in 4.3.2.2. These fields are not protected by the CRC

The structure of the alert I/NAV even and odd page parts on E5b-I and E1-B are defined in Table 36. An alert page is composed by the two page parts (even and odd) transmitted at the same epoch over E5b-I and E1-B (“horizontal page”).

The parameters for the alert page have the following meaning and related values:

- Even/Odd field indicate the part of the page (0=even/1=odd) that is broadcast

E5b-I					E1-B								
Even/odd=0	Page Type	Reserved 1 (1/2)			Tail	Total (bits)	Even/odd=1	Page Type	Reserved 1 (2/2)	CRC	Reserved 2	Tail	Total (bits)
1	1	112			6	120	1	1	80	24	8	6	120
Even/odd=1	Page Type	Reserved 1 (2/2)	CRC	Reserved 2	Tail	Total (bits)	Even/odd=0	Page Type	Reserved 1 (1/2)			Tail	Total (bits)
1	1	80	24	8	6	120	1	1	112			6	120

Table 36. I/NAV Alert Page with Bits Allocation

- Page Type (1 bit) equal to 1 to indicate the alert page type
- CRC (24 bits) computed on the Even/Odd fields, Page Type fields and on Reserved 1 (1/2 and 2/2). In alert mode the CRC is computed for the Even/ Odd pages of both frequencies E5b and E1-B (“horizontal CRC”).
- The Reserved 1 and Reserved 2 fields will be published in a future update of this ICD. Note that the reserved 2 fields are not protected by CRC.
- Tail bits (2\*6 bits) as defined in 4.3.2.2.

### 4.3.3. I/NAV Nominal Sub-Frame Layout

In the nominal mode, the page sequence for I/NAV E5b-I and I/NAV E1-B components in every sub-frame is according to Table 37 where  $T_0$  is synchronized with GST origin modulo 30 seconds

$T_0$ (GST <sub>0</sub> sync.) (s)	ESb Sub frame ID	ESb-I Page	ESb-I Content				E1-B Content						E1-B Page	E1B Sub frame ID
0	N	Even	Word 1 (1/2)				Spare Word (2/2)	Res	SAR	Spare	CRC	Res	Odd	N-1
1	N	Odd	Word 1 (2/2)	Res	CRC	Res	Word 2 (1/2)						Even	N
2	N	Even	Word 3 (1/2)				Word 2 (2/2)	Res	SAR	Spare	CRC	Res	Odd	N
3	N	Odd	Word 3 (2/2)	Res	CRC	Res	Word 4 (1/2)						Even	N
4	N	Even	Word 5 (1/2)				Word 4 (2/2)	Res	SAR	Spare	CRC	Res	Odd	N
5	N	Odd	Word 5 (2/2)	Res	CRC	Res	Word 6 (1/2)						Even	N
6	N	Even	Word 7 or 9 (1/2)*				Word 6 (2/2)	Res	SAR	Spare	CRC	Res	Odd	N
7	N	Odd	Word 7 or 9 (2/2)*	Res	CRC	Res	Word 7 or 9 (1/2)*						Even	N
8	N	Even	Word 8 or 10 (1/2)*				Word 7 or 9 (2/2)*	Res	SAR	Spare	CRC	Res	Odd	N
9	N	Odd	Word 8 or 10 (2/2)*	Res	CRC	Res	Word 8 or 10 (1/2)*						Even	N
10	N	Even	Reserved (1/2)				Word 8 or 10 (2/2)*	Res	SAR	Spare	CRC	Res	Odd	N
11	N	Odd	Reserved (2/2)	CRC	Res	Reserved (1/2)						Even	N	
12	N	Even	Reserved (1/2)				Reserved (2/2)	SAR	Spare	CRC	Res	Odd	N	
13	N	Odd	Reserved (2/2)	CRC	Res	Reserved (1/2)						Even	N	
14	N	Even	Reserved (1/2)				Reserved (2/2)	SAR	Spare	CRC	Res	Odd	N	
15	N	Odd	Reserved (2/2)	CRC	Res	Reserved (1/2)						Even	N	
16	N	Even	Reserved (1/2)				Reserved (2/2)	SAR	Spare	CRC	Res	Odd	N	
17	N	Odd	Reserved (2/2)	CRC	Res	Reserved (1/2)						Even	N	
18	N	Even	Reserved (1/2)				Reserved (2/2)	SAR	Spare	CRC	Res	Odd	N	
19	N	Odd	Reserved (2/2)	CRC	Res	Reserved (1/2)						Even	N	
20	N	Even	Word 2 (1/2)				Reserved (2/2)	SAR	Spare	CRC	Res	Odd	N	
21	N	Odd	Word 2 (2/2)	Res	CRC	Res	Word 1 (1/2)						Even	N
22	N	Even	Word 4 (1/2)				Word 1 (2/2)	Res	SAR	Spare	CRC	Res	Odd	N
23	N	Odd	Word 4 (2/2)	Res	CRC	Res	Word 3 (1/2)						Even	N
24	N	Even	Word 6 (1/2)				Word 3 (2/2)	Res	SAR	Spare	CRC	Res	Odd	N

T <sub>0</sub> (GST <sub>0</sub> sync.) (s)	ESb Sub frame ID	ESb-I Page	ESb-I Content				E1-B Content					E1-B Page	E1B Sub frame ID	
			Word 6 (2/2)	Res	CRC	Res	Word 5 (1/2)							
25	N	Odd	Word 6 (2/2)	Res	CRC	Res	Word 5 (1/2)					Even	N	
26	N	Even	Spare Word (1/2)				Word 5 (2/2)	Res	SAR	Spare	CRC	Res	Odd	N
27	N	Odd	Spare Word (2/2)	Res	CRC	Res	Spare Word (1/2)					Even	N	
28	N	Even	Spare Word (1/2)				Spare Word (2/2)	Res	SAR	Spare	CRC	Res	Odd	N
29	N	Odd	Spare Word (2/2)	Res	CRC	Res	Spare Word (1/2)					Even	N	
30	N+1	Even	Word 1 (1/2)				Spare Word (2/2)	Res	SAR	Spare	CRC	Res	Odd	N

Table 37. I/Nav Nominal Sub-Frame Structure

\* The dissemination sequence of Word Types 7, 8, 9 and 10 within a frame is detailed in Table 38.

#### 4.3.4. I/NAV Nominal Frame Layout

The I/NAV sub-frames containing almanac data are sequenced in a nominal frame according to Table 38.

T <sub>0</sub> (s)	Sub- frame ID	ESb	E1B
0	1	Word 7: Almanac SV 1 (1/2)	Word 7: Almanac SV 19 (1/2)
		Word 8: Almanac SV 1 (2/2) + almanac SV 2 (1/2)	Word 8: Almanac SV 19 (2/2) + almanac SV 20 (1/2)
30	2	Word 9: Almanac SV 2 (2/2) + almanac SV 3 (1/2)	Word 9: Almanac SV 20 (2/2) + almanac SV 21 (1/2)
		Word 10: Almanac SV 3 (2/2)	Word 10: Almanac SV 21 (2/2)
60	3	Word 7: Almanac SV 4 (1/2)	Word 7: Almanac SV 22 (1/2)
		Word 8: Almanac SV 4 (2/2) + almanac SV 5 (1/2)	Word 8: Almanac SV 22 (2/2) + almanac SV 23 (1/2)
90	4	Word 9: Almanac SV 5 (2/2) + almanac SV 6 (1/2)	Word 9: Almanac SV 23 (2/2) + almanac SV 24 (1/2)
		Word 10: Almanac SV 6 (2/2)	Word 10: Almanac SV 24 (2/2)
120	5	Word 7: Almanac SV 7 (1/2)	Word 7: Almanac SV 25 (1/2)
		Word 8: Almanac SV 7 (2/2) + almanac SV 8 (1/2)	Word 8: Almanac SV 25 (2/2) + almanac SV 26 (1/2)
150	6	Word 9: Almanac SV 8 (2/2) + almanac SV 9 (1/2)	Word 9: Almanac SV 26 (2/2) + almanac SV 27 (1/2)
		Word 10: Almanac SV 9 (2/2)	Word 10: Almanac SV 27 (2/2)
180	7	Word 7: Almanac SV 10 (1/2)	Word 7: Almanac SV 28 (1/2)
		Word 8: Almanac SV 10 (2/2) + almanac SV 11 (1/2)	Word 8: Almanac SV 28 (2/2) + almanac SV 29 (1/2)
210	8	Word 9: Almanac SV 11 (2/2) + almanac SV 12 (1/2)	Word 9: Almanac SV 29 (2/2) + almanac SV 30 (1/2)
		Word 10: Almanac SV 12 (2/2)	Word 10: Almanac SV 30 (2/2)
240	9	Word 7: Almanac SV 13 (1/2)	Word 7: Almanac SV 31 (1/2)
		Word 8: Almanac SV 13 (2/2) + almanac SV 14 (1/2)	Word 8: Almanac SV 31 (2/2) + almanac SV 32 (1/2)

<b>T<sub>0</sub> (s)</b>	<b>Sub-frame ID</b>	<b>E5b</b>	<b>E1B</b>
270	10	Word 9: Almanac SV 14 (2/2) + almanac SV 15 (1/2)	Word 9: Almanac SV 32 (2/2) + almanac SV 33 (1/2)
		Word 10: Almanac SV 15 (2/2)	Word 10: Almanac SV 33 (2/2)
300	11	Word 7: Almanac SV 16 (1/2)	Word 7: Almanac SV 34 (1/2)
		Word 8: Almanac SV 16 (2/2) + almanac SV 17 (1/2)	Word 8: Almanac SV 34 (2/2) + almanac SV 35 (1/2)
330	12	Word 9: Almanac SV 17 (2/2) + almanac SV 18 (1/2)	Word 9: Almanac SV 35 (2/2) + almanac SV 36 (1/2)
		Word 10: Almanac SV 18 (2/2)	Word 10: Almanac SV 36 (2/2)
360	13	Word 7: Almanac SV 19 (1/2)	Word 7: Almanac SV 1 (1/2)
		Word 8: Almanac SV 19 (2/2) + almanac SV 20 (1/2)	Word 8: Almanac SV 1 (2/2) + almanac SV 2 (1/2)
390	14	Word 9: Almanac SV 20 (2/2) + almanac SV 21 (1/2)	Word 9: Almanac SV 2 (2/2) + almanac SV 3 (1/2)
		Word 10: Almanac SV 21 (2/2)	Word 10: Almanac SV 3 (2/2)
420	15	Word 7: Almanac SV 22 (1/2)	Word 7: Almanac SV 4 (1/2)
		Word 8: Almanac SV 22 (2/2) + almanac SV 23 (1/2)	Word 8: Almanac SV 4 (2/2) + almanac SV 5 (1/2)
450	16	Word 9: Almanac SV 23 (2/2) + almanac SV 24 (1/2)	Word 9: Almanac SV 5 (2/2) + almanac SV 6 (1/2)
		Word 10: Almanac SV 24 (2/2)	Word 10: Almanac SV 6 (2/2)
480	17	Word 7: Almanac SV 25 (1/2)	Word 7: Almanac SV 7 (1/2)
		Word 8: Almanac SV 25 (2/2) + almanac SV 26 (1/2)	Word 8: Almanac SV 7 (2/2) + almanac SV 8 (1/2)
510	18	Word 9: Almanac SV 26 (2/2) + almanac SV 27 (1/2)	Word 9: Almanac SV 8 (2/2) + almanac SV 9 (1/2)
		Word 10: Almanac SV 27 (2/2)	Word 10: Almanac SV 9 (2/2)
540	19	Word 7: Almanac SV 28 (1/2)	Word 7: Almanac SV 10 (1/2)
		Word 8: Almanac SV 28 (2/2) + almanac SV 29 (1/2)	Word 8: Almanac SV 10 (2/2) + almanac SV 11 (1/2)
570	20	Word 9: Almanac SV 29 (2/2) + almanac SV 30 (1/2)	Word 9: Almanac SV 11 (2/2) + almanac SV 12 (1/2)
		Word 10: Almanac SV 30 (2/2)	Word 10: Almanac SV 12 (2/2)
600	21	Word 7: Almanac SV 31 (1/2)	Word 7: Almanac SV 13 (1/2)
		Word 8: Almanac SV 31 (2/2) + almanac SV 32 (1/2)	Word 8: Almanac SV 13 (2/2) + almanac SV 14 (1/2)
630	22	Word 9: Almanac SV 32 (2/2) + almanac SV 33 (1/2)	Word 9: Almanac SV 14 (2/2) + almanac SV 15 (1/2)
		Word 10: Almanac SV 33 (2/2)	Word 10: Almanac SV 15 (2/2)
660	23	Word 7: Almanac SV 34 (1/2)	Word 7: Almanac SV 16 (1/2)
		Word 8: Almanac SV 34 (2/2) + almanac SV 35 (1/2)	Word 8: Almanac SV 16 (2/2) + almanac SV 17 (1/2)
690	24	Word 9: Almanac SV 35 (2/2) + almanac SV 36 (1/2)	Word 9: Almanac SV 17 (2/2) + almanac SV 18 (1/2)
		Word 10: Almanac SV 36 (2/2)	Word 10: Almanac SV 18 (2/2)

Table 38. I/NAV Sub-Frame Sequencing

#### 4.3.5. I/NAV Word Types

The content of the I/NAV word types is stated in the following tables (see Chapter 5 for a description of the I/NAV word types contents).

Word Type 1: Ephemeris (1/4)

Type=1	IOD <sub>nav</sub>	Ephemeris (1/4)				Reserved	Total (bits)
		$t_{0e}$	$M_0$	$e$	$A^{1/2}$		
6	10	14	32	32	32	2	128

Table 39. Bits Allocation for I/NAV Word Type 1

Word Type 2: Ephemeris (2/4)

Type=2	IOD <sub>nav</sub>	Ephemeris (2/4)				Reserved	Total (bits)
		$\Omega_0$	$i_0$	$\omega$	$i$		
6	10	32	32	32	14	2	128

Table 40. Bits Allocation for I/NAV Word Type 2

Word Type 3: Ephemeris (3/4) and SISA

Type=3	IOD <sub>nav</sub>	Ephemeris (3/4)						SISA(E1,E5b)	Total (bits)
		$\dot{\Omega}$	$\Delta n$	$C_{UC}$	$C_{US}$	$C_{RC}$	$C_{RS}$		
6	10	24	16	16	16	16	16	8	128

Table 41. Bits Allocation for I/NAV Word Type 3

Word Type 4: SVID, Ephemeris (4/4), and Clock correction parameters

Type=4	IOD <sub>nav</sub>	SVID	Ephemeris (4/4)		Clock correction				Spare	Total (bits)
			$C_{ic}$	$C_{is}$	$t_{0c}$	$a_{f0}$	$a_{f1}$	$a_{f2}$		
6	10	6	16	16	14	31	21	6	2	128

Table 42. Bits Allocation for I/NAV Word Type 4

Word Type 5: Ionospheric correction, BGD, signal health and data validity status and GST

Type=5	Ionospheric correction								BGD(E1,E5a)	BGD(E1,E5b)	E5b <sub>HS</sub>	E1B <sub>HS</sub>	E5b <sub>pvs</sub>	E1B <sub>pvs</sub>	GST		Spare	Total (bits)
	Az			Ionospheric disturbance flag											WN	TOW		
	$a_{i0}$	$a_{i1}$	$a_{i2}$	Region 1	Region 2	Region 3	Region 4	Region 5										
6	11	11	14	1	1	1	1	1	10	10	2	2	1	1	12	20	23	128

Table 43. Bits Allocation for I/NAV Word Type 5

Word Type 6: GST-UTC conversion parameters

Type=6	GST-UTC conversion parameters									TOW	Spare	Total (bits)
	$A_0$	$A_1$	$\Delta t_{LS}$	$t_{ot}$	$WN_{0r}$	$WN_{LSF}$	$DN$	$\Delta t_{LSF}$				
6	32	24	8	8	8	8	3	8	20	3	128	

Table 44. Bits Allocation for I/NAV Word Type 6

Word Type 7: Almanac for SVID1 (1/2), almanac reference time and almanac reference week number

Type=7	IOD <sub>a</sub>	WN <sub>a</sub>	$t_{0a}$	SV <sub>SVID1</sub> (1/2)								Reserved	Total (bits)
				SVID1	$\Delta(A^{1/2})$	$e$	$\omega$	$\delta_i$	$\Omega_0$	$\dot{\Omega}$	$M_0$		
6	4	2	10	6	13	11	16	11	16	11	16	6	128

Table 45. Bits Allocation for I/NAV Word Type 7

Word Type 8: Almanac for SVID1 (2/2) and SVID2 (1/2)

Type=8	IOD <sub>a</sub>	SV <sub>SVID1</sub> (2/2)				SV <sub>SVID2</sub> (1/2)					Spare	Total (bits)		
		$a_{f0}$	$a_{f1}$	E5b <sub>HS</sub>	E1B <sub>HS</sub>	SVID2	$\Delta(A^{1/2})$	$e$	$\omega$	$\delta_i$			$\Omega_0$	$\dot{\Omega}$
6	4	16	13	2	2	6	13	11	16	11	16	11	1	128

Table 46. Bits Allocation for I/NAV Word Type 8

Word Type 9: Almanac for SVID2 (2/2) and SVID3 (1/2)

Type=9	IOD <sub>a</sub>	WN <sub>a</sub>	$t_{0a}$	SV <sub>SVID2</sub> (2/2)					SV <sub>SVID3</sub> (1/2)					Total (bits)
				$M_0$	$a_{f0}$	$a_{f1}$	E5b <sub>HS</sub>	E1B <sub>HS</sub>	SVID3	$\Delta(A^{1/2})$	$e$	$\omega$	$\delta_i$	
6	4	2	10	16	16	13	2	2	6	13	11	16	11	128

Table 47. Bits Allocation for I/NAV Word Type 9

Word type 10: Almanac for SVID3 (2/2) and GST-GPS conversion parameters

Type=10	IOD <sub>a</sub>	SV <sub>SVID3</sub> (2/2)							GST-GPS conversion parameters				Total (bits)
		$\Omega_0$	$\dot{\Omega}$	$M_0$	$a_{f0}$	$a_{f1}$	E5b <sub>HS</sub>	E1B <sub>HS</sub>	$A_{0G}$	$A_{1G}$	$t_{0G}$	$WN_{0G}$	
6	4	16	11	16	16	13	2	2	16	12	8	6	128

Table 48. Bits Allocation for I/NAV Word Type 10



#### Word Type 0: I/NAV Spare Word

Type=0	Time	Spare	GST		Total (bits)
			WN	TOW	
6	2	88	12	20	128

Table 49. Bits Allocation for Spare Word

When the field 'Time' is not set to '10', the fields WN and TOW do not contain valid data.

#### 4.3.6. I/NAV Dummy Message Layout

In case no valid I/NAV data is to be transmitted, the satellite generates and downlinks the dummy message on E5b-I and E1-B components replacing the pages in the nominal sequencing, according to the Dummy pages layout defined in Table 50.

E5b-I						E1-B								
Even/odd=0	Page Type	Dummy data (1/2)				Tail	Total (bits)	Even/odd=1	Page Type	Dummy data (2/2)	CRC	Spare	Tail	Total (bits)
1	1	112				6	120	1	1	80	24	8	6	120
Even/odd=1	Page Type	Dummy data (2/2)	CRC	Spare	Tail	Total (bits)	Even/odd=0	Page Type	Dummy data (1/2)				Tail	Total (bits)
1	1	80	24	8	6	120	1	1	112				6	120

Table 50. I/NAV Dummy Page with Bits Allocation

The parameters for the dummy page have the following meaning and related values:

- Even/Odd (1 bit) to indicate the part of the page (0=even/1=odd) that is broadcast
- Page Type (1 bit) equal to 0 to indicate the nominal page type
- Dummy Data (192 bits = 80 bits + 112 bits)
- CRC (24 bits): computed on the Even/odd fields, Type fields and Dummy data fields (1/2 and 2/2) for the Even/Odd page of the same frequency ("vertical CRC"), and the CRC is always broadcast on the second part of the "vertical page"
- Spare (8 bits). This field is not protected by the CRC
- Tail bits (2\*6 bits) as defined in 4.3.2.2. These fields are not protected by the CRC

The dummy data word is formatted according to Table 51, with

- Word Type (6 bits) to indicate the word type dummy message, which is defined as type 63
- The dummy sequence (186 bits) is an arbitrary sequence

Type = 63	Dummy Sequence		Total (bits)
6	186		
Dummy Data (1/2) (112 bits)		Dummy Data (2/2) (80 bits)	

Table 51. Dummy Word with Bits Allocation

#### 4.3.7. SAR Field Structure

In the nominal mode the SAR RLM is transmitted only in the E1-B component. The SAR field structure for the E1-B component in nominal mode is formatted according to the values stated in Table 52. When an alert is present, the SAR data will not be transmitted

SAR Data			Total (bits)
Start Bit	Short/Long RLM Identifier	SAR RLM Data	
1	1	20	22

Table 52. SAR Field Bit Structure

The RLM identifier bit is described in the following table.

RLM Identifier Value	Description
0	Short RLM
1	Long RLM

Table 53. RLM Identifier Description

#### SAR data in Nominal Mode

In nominal mode, 22 bits are allocated to SAR data in one E1-B I/NAV page. The SAR messages are formatted according to the values and structure stated in Table 54 and Table 55 respectively for the short RLM and the long RLM. This structure allows the downlink of a short RLM within 8 seconds and of a long RLM within 16 seconds. The content of the SAR data is provided in paragraph 5.2.

- Short RLM

Part (1/4)			Part (2/4)			Part (3/4)			Part (4/4)			
Start bit = 1	Short RLM	SAR RLM data	Start bit = 0	Short RLM	SAR RLM data	Start bit = 0	Short RLM	SAR RLM data	Start bit = 0	Short RLM	SAR RLM data	
		Beacon ID (1/3)			Beacon ID (2/3)			Beacon ID (3/3)			Message code	Parameters
1	1	20	1	1	20	1	1	20	1	1	4	16
22			22			22			22			

Table 54. SAR Short RLM

- Long RLM

Part (1/8)			Part (2/8)			Part (3/8)			Part (4/8)			
Start bit = 1	Long RLM	SAR RLM data	Start bit = 0	Long RLM	SAR RLM data	Start bit = 0	Long RLM	SAR RLM data	Start bit = 0	Long RLM	SAR RLM data	
		Beacon ID (1/3)			Beacon ID (2/3)			Beacon ID (3/3)			Message code	Parameters (1/5)
1	1	20	1	1	20	1	1	20	1	1	4	16
22			22			22			22			

Part (5/8)			Part (6/8)			Part (7/8)			Part (8/8)			
Start bit = 0	Long RLM	SAR RLM data	Start bit = 0	Long RLM	SAR RLM data	Start bit = 0	Long RLM	SAR RLM data	Start bit = 0	Long RLM	SAR RLM data	
		Parameters (2/5)			Parameters (3/5)			Parameters (4/5)			Parameters (5/5)	
1	1	20	1	1	20	1	1	20	1	1	20	
22			22			22			22			

Table 55. SAR Long RLM

### Spare SAR Data

In case no valid SAR data is to be transmitted, the satellite generates the spare SAR data field according to Table 56.

SAR Data		Total (bits)
Start Bit = 1	Spare	
1	21	22

Table 56. Spare SAR Data

A SAR receiver will use the sequence of start bits (and only these) to identify SAR data parts belonging to SAR RLMs. If the start bit of the current data part is equal to zero, then the data part contains SAR relevant data. If the start bit of the current data part is equal to one, the data part contains SAR relevant data only if the start bit of the next (immediately subsequent) data part is equal to zero.

## 5. Message Data Contents

This section describes the data items above mentioned. Semantics, formats and other characteristics are provided for all items to be transmitted inside frames.

### 5.1. Navigation Data

The navigation data contain all the parameters required for the user to compute a complete position, velocity and time (PVT) solution. They are stored on board each satellite with a validity duration and broadcast world-wide by all the satellites of the Galileo constellation. The 4 types of data needed to perform positioning are:

- Ephemeris parameters, which are needed to indicate the position of the satellite to the user receiver
- Time and clock correction parameters which are needed to compute pseudo-range
- Service parameters which are needed to identify the set of navigation data, satellites, and indicators of the signal health
- Almanac parameters, which are needed to indicate the position of all the satellites in the constellation with a reduced accuracy

#### 5.1.1. Ephemeris

The ephemeris for each Galileo satellite is composed of 16 parameters, which are:

- 6 Keplerian parameters
- 6 harmonic coefficients
- 1 orbit inclination rate parameter
- 1 RAAN rate parameter
- 1 mean motion correction parameter, and
- 1 reference time parameter  $t_{0e}$  for the ephemeris data set

The ephemeris for each Galileo satellite is according to the characteristics stated in Table 57.

Parameter	Definition	Bits	Scale factor	Unit
$M_0$	Mean anomaly at reference time	32*	$2^{-31}$	semi-circles**
$\Delta n$	Mean motion difference from computed value	16*	$2^{-43}$	semi-circles/s**
$e$	Eccentricity	32	$2^{-33}$	N/A
$A^{1/2}$	Square root of the semi-major axis	32	$2^{-19}$	meter <sup>1/2</sup>
$\Omega_0$	Longitude of ascending node of orbital plane at weekly epoch***	32*	$2^{-31}$	semi-circles**
$i_0$	Inclination angle at reference time	32*	$2^{-31}$	semi-circles**
$\omega$	Argument of perigee	32*	$2^{-31}$	semi-circles**

Parameter	Definition	Bits	Scale factor	Unit
$\dot{\Omega}$	Rate of change of right ascension	24*	2 <sup>-43</sup>	semi-circles/s**
$\dot{i}$	Rate of change of inclination angle	14*	2 <sup>-43</sup>	semi-circles/s**
$C_{uc}$	Amplitude of the cosine harmonic correction term to the argument of latitude	16*	2 <sup>-29</sup>	radians
$C_{us}$	Amplitude of the sine harmonic correction term to the argument of latitude	16*	2 <sup>-29</sup>	radians
$C_{rc}$	Amplitude of the cosine harmonic correction term to the orbit radius	16*	2 <sup>-5</sup>	meters
$C_{rs}$	Amplitude of the sine harmonic correction term to the orbit radius	16*	2 <sup>-5</sup>	meters
$C_{ic}$	Amplitude of the cosine harmonic correction term to the angle of inclination	16*	2 <sup>-29</sup>	radians
$C_{is}$	Amplitude of the sine harmonic correction term to the angle of inclination	16*	2 <sup>-29</sup>	radians
$t_{0e}$	Ephemeris reference time	14	60	seconds
<b>Total Ephemeris Size</b>		<b>356</b>		

Table 57. Ephemeris Parameters

- \* Parameters so indicated are two's complement, with the sign bit (+ or -) occupying the MSB.
- \*\* Note that the 'semi-circle' is not a SI unit but can be converted as: 1 semi-circle =  $\pi$  rad.
- \*\*\* More precisely,  $\Omega_0$  is the longitude of ascending node of orbital plane at the weekly epoch propagated to the reference time  $t_{0e}$  at the rate of change of right ascension.

A single ephemeris is applicable to all signals of a specific satellite. The ephemeris is computed with respect to the apparent CoP common to every frequency.

The user can compute the ECEF coordinates of the SV's antenna phase centre position at GST time  $t$  utilizing the equations shown in Table 58.

Constant	Description
$\pi = 3.1415926535898$	Ratio of a circle's circumference to its diameter
$\mu = 3.986004418 \times 10^{14} \text{ m}^3/\text{s}^2$	Geocentric gravitational constant
$\omega_E = 7.2921151467 \times 10^{-5} \text{ rad/s}$	Mean angular velocity of the Earth
$c = 299792458 \text{ m/s}$	Speed of light

Computation	Description
$A = (A^{1/2})^2$	Semi-major axis
$n_0 = \sqrt{\frac{\mu}{A^3}}$	Computed mean motion (rad/s)
$t_k = t - t_{0e}^*$	Time from ephemeris reference epoch
$n = n_0 + \Delta n$	Corrected mean motion
$M = M_0 + n t_k$	Mean anomaly
$M = E - e \sin(E)$	Kepler's Equation for Eccentric Anomaly $E$ (may be solved by iteration)

Computation	Description
$v = \tan^{-1} \left\{ \frac{\sin v}{\cos v} \right\}$ $= \tan^{-1} \left\{ \frac{\sqrt{1-e^2} \sin E / (1-e \cos E)}{(\cos E - e) / (1-e \cos E)} \right\}$	True Anomaly
$\Phi = v + \omega$	Argument of Latitude
$\delta u = C_{us} \sin 2\Phi + C_{uc} \cos 2\Phi$	Argument of Latitude Correction
$\delta r = C_{rs} \sin 2\Phi + C_{rc} \cos 2\Phi$	Radius Correction
$\delta i = C_{is} \sin 2\Phi + C_{ic} \cos 2\Phi$	Inclination Correction
$u = \Phi + \delta u$	Corrected Argument of Latitude
$r = A(1-e \cos E) + \delta r$	Corrected Radius
$i = i_0 + \delta i + \dot{i} t_k$	Corrected Inclination
$\left. \begin{aligned} x' &= r \cos u \\ y' &= r \sin u \end{aligned} \right\}$	Position in orbital plane
$\Omega = \Omega_0 + \left[ \dot{\Omega} - \omega_E \right] t_k - \omega_E t_{0e}$	Corrected longitude of ascending node
$\left. \begin{aligned} x &= x' \cos(\Omega) - y' \cos(i) \sin(\Omega) \\ y &= x' \sin(\Omega) + y' \cos(i) \cos(\Omega) \\ z &= y' \sin(i) \end{aligned} \right\}$	GTRF coordinates of the SV antenna phase center position at time t

Table 58. User Algorithm for Ephemeris Determination

\*  $t$  is Galileo System Time (see e.g. paragraph 5.1.2). Furthermore,  $t_k$  is the actual total time difference between the time  $t$  and the epoch time  $t_{0e}$  ( $t_{0a}$  for the almanacs) and it accounts for beginning or end of week crossovers.

### 5.1.2. Galileo System Time (GST)

The GST is given as 32-bit binary number composed of two parameters as follows:

- The Week Number is an integer counter that gives the sequential week number from the GST start epoch. This parameter is represented with 12 bits, which covers 4096 weeks (about 78 years). Then the counter is reset to zero to cover an additional period modulo 4096.
- The Time of Week is defined as the number of seconds that have occurred since the transition from the previous week. The *TOW* covers an entire week from 0 to 604799 seconds and is reset to zero at the end of each week.

The GST parameters are transmitted according to the characteristics stated in Table 59.

Parameter	Definition	Bits	Scale factor	Unit
<i>WN</i>	Week Number	12	1	week
<i>TOW</i>	Time of Week	20	1	s
<b>Total Galileo System Time Size</b>		<b>32</b>		

Table 59. GST Parameters

The GST start epoch is defined as 13 seconds before midnight between 21<sup>st</sup> August and 22<sup>nd</sup> August 1999, i.e. GST was equal to 13 seconds at 22-08-1999 00:00:00 UTC.

As GST is a continuous time scale, and UTC is corrected periodically with an integer number of leap seconds, the Galileo navigation message contains all necessary parameters to convert between GST and UTC.

The epoch denoted in the navigation messages by  $TOW$  and  $WN$  will be measured relative to the leading edge of the first chip of the first code sequence of the first page symbol. The transmission timing of the navigation message provided through the  $TOW$  is synchronised to each satellite's version of Galileo System Time (GST).

### 5.1.3. Clock Correction Parameters

The clock correction parameters are transmitted according to the values stated in Table 60.

Parameter	Definition	Bits	Scale factor	Unit
$t_{0c}$	Clock correction data reference Time of Week	14	60	s
$a_{f0}$	SV clock bias correction coefficient	31*	$2^{-34}$	s
$a_{f1}$	SV clock drift correction coefficient	21*	$2^{-46}$	s/s
$a_{f2}$	SV clock drift rate correction coefficient	6*	$2^{-59}$	s/s <sup>2</sup>
<b>Total Clock Correction Size</b>		<b>72</b>		

Table 60. Galileo Clock Correction Parameters

\* Parameters so indicated are two's complement, with the sign bit (+ or -) occupying the MSB.

Each Galileo satellite broadcasts its own clock correction data for all signals through the relevant signal, according to Table 61.

Message Type	Clock Model $X=(f1,f2)$	Satellite Time Correction Model Parameters	Services
F/Nav	(E1,E5a)	$a_{f0}$ (E1,E5a) $a_{f1}$ (E1,E5a) $a_{f2}$ (E1,E5a) $t_{0C}$ (E1,E5a)	Dual-Frequency (E1,E5a) Single-frequency E5a
I/NAV	(E1,E5b)	$a_{f0}$ (E1,E5b) $a_{f1}$ (E1,E5b) $a_{f2}$ (E1,E5b) $t_{0C}$ (E1,E5b)	Dual-Frequency (E1,E5b) Single-frequency E5b Single-frequency E1

Table 61. Galileo Clock Correction Data

### 5.1.4. Satellite Time Correction Algorithm

Each satellite transmits time correction data. The predicted offset of the physical satellite signal TOT relative to the satellite signal TOT in GST can be computed for the dual frequency signal combination using the following formula:

$$TOT_c(X) = TOT_m(X) - \Delta t_{SV}(X) \quad \text{Eq. 12}$$

where

- $(X)=(f_1,f_2)$  is the dual frequency combination  $f_1$  and  $f_2$  used for the clock model
- $TOT_c(X)$  is the corrected satellite TOT in GST for the signal combination  $X$
- $TOT_m(X)$  is the physical satellite TOT for the signal combination  $X$  retrieved through pseudo-range measurements
- $\Delta t_{SV}(X)$  is the satellite time correction for the signal combination  $X$  computed by means of the time correction data retrieved from the navigation message

This satellite time correction (in seconds) is modelled through the following second order polynomial:

$$\Delta t_{SV}(X) = a_{f0}(X) + a_{f1}(X)[t - t_{0C}(X)] + a_{f2}(X)[t - t_{0C}(X)]^2 + \Delta t_r \quad \text{Eq. 13}$$

where

- $a_{f0}(X)$ ,  $a_{f1}(X)$ , and  $a_{f2}(X)$  are defined in 5.1.3
- $t_{0C}(X)$  is the reference time for the clock correction as defined in 5.1.3
- $t$  is the GST time in seconds
- $\Delta t_r$ , expressed in seconds, is a relativistic correction term, given by

$$\Delta t_r = F e A^{1/2} \sin(E)$$

with the orbital parameters ( $e$ ,  $A^{1/2}$ ,  $E$ ) as described in paragraph 5.1.1 and

$$F = -2\mu^{1/2}/c^2 = -4.442807309 \times 10^{-10} \text{ s/m}^{1/2}$$

### 5.1.5. Broadcast Group Delay

The Broadcast Group Delay  $BGD(f_1, f_2)$  broadcast through the Galileo navigation message is defined as follows:

$$BGD(f_1, f_2) = \frac{TR_1 - TR_2}{1 - \left(\frac{f_1}{f_2}\right)^2} \quad \text{Eq. 14}$$

where

- $f_1$  and  $f_2$  denote the carrier frequencies of two Galileo signals
- $TR_1$  and  $TR_2$  are the group delays of the signals whose carrier frequencies are respectively  $f_1$  and  $f_2$ .

A single frequency user receiver processing pseudo-ranges from the frequency  $f_1$  applies the following correction to the SV clock correction  $\Delta t_{SV}$  which is defined in paragraph 5.1.4

$$\Delta t_{SV}(f_1) = \Delta t_{SV}(f_1, f_2) - BGD(f_1, f_2) \quad \text{Eq. 15}$$

A single frequency user receiver processing pseudo-ranges from the frequency  $f_2$  applies the following correction to the SV clock correction  $\Delta t_{SV}$  which is defined in paragraph 5.1.4

$$\Delta t_{SV}(f_2) = \Delta t_{SV}(f_1, f_2) - \left(\frac{f_1}{f_2}\right)^2 BGD(f_1, f_2) \quad \text{Eq. 16}$$

A dual frequency user receiver processing pseudo-ranges from the two frequencies  $f_1$  and  $f_2$  does not apply any additional correction for group delay. The Broadcast Group Delay is coded according to the values stated in Table 62.

Parameter	Definition	Bits	Scale factor	Unit
$BGD(E1, E5a)$	E1-E5a Broadcast Group Delay	10*	$2^{-32}$	s
$BGD(E1, E5b)$	E1-E5b Broadcast Group Delay	10*	$2^{-32}$	s

Table 62. BGD Parameters

\* Parameters so indicated are two's complement, with the sign bit (+ or -) occupying the MSB.



Each Galileo satellite broadcasts its own BGD data for all signals, through the relevant signal according to Table 63.

Message Type	Type of Satellite Clocks	BGD( $f_1, f_2$ )	Services
F/NAV	(E1,E5a)	$BGD(E1, E5a)$	Single-frequency E5a
I/NAV	(E1,E5b)	$BGD(E1, E5b)$	Single-frequency E1 Single-frequency E5b

Table 63. BGD Values Mapping on Messages and Services

### 5.1.6. Ionospheric Correction

The ionospheric model parameters include:

- the broadcast coefficients  $a_{i0}$ ,  $a_{i1}$  and  $a_{i2}$  used to compute the Effective Ionisation Level  $A_z$
- the “Ionospheric Disturbance Flag” (also referred as “storm flag”), given for five different regions

These parameters are transmitted according to the characteristics stated in Table 64.

Parameter	Definition	Bits	Scale factor	Unit
$a_{i0}$	Effective Ionisation Level 1 <sup>st</sup> order parameter	11	2 <sup>-2</sup>	sfu**
$a_{i1}$	Effective Ionisation Level 2 <sup>nd</sup> order parameter	11*	2 <sup>-8</sup>	sfu**/degree
$a_{i2}$	Effective Ionisation Level 3 <sup>rd</sup> order parameter	14*	2 <sup>-15</sup>	sfu**/degree <sup>2</sup>
SF <sub>1</sub>	Ionospheric Disturbance Flag for region 1	1	N/A	dimensionless
SF <sub>2</sub>	Ionospheric Disturbance Flag for region 2	1	N/A	dimensionless
SF <sub>3</sub>	Ionospheric Disturbance Flag for region 3	1	N/A	dimensionless
SF <sub>4</sub>	Ionospheric Disturbance Flag for region 4	1	N/A	dimensionless
SF <sub>5</sub>	Ionospheric Disturbance Flag for region 5	1	N/A	dimensionless
<b>Total Ionosphere Correction Size</b>		<b>41</b>		

Table 64. Ionospheric Correction Parameters

\* Parameters so indicated are two’s complement, with the sign bit (+ or -) occupying the MSB.

\*\* Note that ‘sfu’ (solar flux unit) is not a SI unit but can be converted as: 1 sfu = 10<sup>-22</sup> W/(m<sup>2</sup>\*Hz)

The effective ionisation level is computed according to the equation below where  $\mu$  is the modified dip latitude MODIP.

$$A_z = a_{i0} + a_{i1}\mu + a_{i2}\mu^2 \quad \text{Eq. 17}$$

The Ionospheric Disturbance Flag has the following values: [0:No disturbance,1:Disturbance] in the region, where the regions are defined as:

- region 1: for the northern region (60°<MODIP≤90°)
- region 2: for the northern middle region (30°<MODIP≤60°)
- region 3: for the equatorial region (-30°≤MODIP≤30°)
- region 4: for the southern middle region (-60°≤MODIP<-30°)
- region 5: for the southern region (-90°≤MODIP<-60°)

### 5.1.7. GST-UTC Conversion Algorithm and Parameters

The UTC time  $t_{UTC}$  is computed through 3 different cases depending on the epoch of a possible leap second adjustment (scheduled future or recent past) given by  $DN$ , the day at the end of which the leap second becomes effective, and week number  $WN_{LSF}$  to which  $DN$  is referenced. “Day one” of  $DN$  is the first day relative to the end/start of week and  $WN_{LSF}$  is the Galileo week number modulo 256.

Parameter	Definition	Bits	Scale factor	Unit
$A_0$	Constant term of polynomial	32*	2 <sup>-30</sup>	s
$A_1$	1 <sup>st</sup> order term of polynomial	24*	2 <sup>-50</sup>	s/s
$\Delta t_{LS}$	Leap Second count before leap second adjustment	8*	1	s
$t_{0t}$	UTC data reference Time of Week	8	3600	s
$WN_{0t}$	UTC data reference Week Number	8	1	week
$WN_{LSF}$	Week Number of leap second adjustment	8	1	week
$DN$	Day Number at the end of which a leap second adjustment becomes effective	3**	1	day
$\Delta t_{LSF}$	Leap Second count after leap second adjustment	8*	1	s
<b>Total GST-UTC Conversion Size</b>		<b>99</b>		

Table 65. Parameters for the GST-UTC Conversion

\* Parameters so indicated are two's complement, with the sign bit (+ or -) occupying the MSB.

\*\* The value range of  $DN$  is from 1 (= Sunday) to 7 (= Saturday).

In addition to the parameters listed in Table 65, the following parameters are used in GST-UTC conversion algorithm:

- $t_E$  is the GST as estimated by the user through its GST determination algorithm
- $WN$  is the week number to which  $t_E$  is referenced, modulo 256

#### Case a

Whenever the leap second adjustment time indicated by  $WN_{LSF}$  and  $DN$  is not in the past (relative to the user's present time) and the user's present time does not fall in the time span which starts six hours prior to the effective time (=  $DN+3/4$ ) and ends six hours after the effective time at (=  $DN+5/4$ ),  $t_{UTC}$  is computed according to the following equations:

$$t_{UTC} = (t_E - \Delta t_{UTC})[\text{Modulo } 86400] \quad \text{Eq. 18}$$

$$\text{where: } \Delta t_{UTC} = \Delta t_{LS} + A_0 + A_1(t_E - t_{0t} + 604800(WN - WN_{0t}))$$

#### Case b

Whenever the user's current time falls within the time span of six hours prior to the leap second adjustment time to six hours after the adjustment time,  $t_{UTC}$  is computed according to the following equations ( $\Delta t_{UTC}$  as defined in case a):

$$t_{UTC} = W[\text{Modulo}(86400 + \Delta t_{LSF} - \Delta t_{LS})] \quad \text{Eq. 19}$$

$$\text{where: } W = (t_E - \Delta t_{UTC} - 43200)[\text{Modulo } 86400] + 43200$$

#### Case c

Whenever the leap second adjustment time, as indicated by the  $WN_{LSF}$  and  $DN$  values, is in the “past” (relative to the user's current time) and the user's present time does not fall

in the time span which starts six hours prior to the leap second adjustment time and ends six hours after the adjustment time,  $t_{UTC}$  is computed according to the following equation:

$$t_{UTC} = (t_E - \Delta t_{UTC})[\text{Modulo } 86400] \quad \text{Eq. 20}$$

$$\text{where: } \Delta t_{UTC} = \Delta t_{LSF} + A_0 + A_1(t_E - t_{0t} + 604800(WN - WN_{0t}))$$

The parameters for GST to UTC conversion are defined in Table 65.

### 5.1.8. GPS to Galileo System Time Conversion and Parameters

The difference between the Galileo and the GPS time scales, expressed in seconds, is given by the equation below.

$$\Delta t_{systems} = t_{Galileo} - t_{GPS} = A_{0G} + A_{1G}[TOW - t_{0G} + 604800((WN - WN_{0G})[\text{Modulo } 64])] \quad \text{Eq. 21}$$

with

- $A_{0G}$  constant term of the offset  $\Delta t_{systems}$
- $A_{1G}$  rate of change of the offset  $\Delta t_{systems}$
- $t_{0G}$  reference time for GGTO data
- $t_{Galileo}$  GST time (s)
- $t_{GPS}$  GPS time(s)
- $WN$  GST Week Number
- $WN_{0G}$  Week Number of the GPS/Galileo Time Offset reference

The GGTO parameters are formatted according to the values in Table 66.

Parameter	Definition	Bits	Scale factor	Unit
$A_{0G}$	Constant term of the polynomial describing the offset $\Delta t_{systems}$	16*	$2^{-35}$	s
$A_{1G}$	Rate of change of the offset $\Delta t_{systems}$	12*	$2^{-51}$	s/s
$t_{0G}$	Reference time for GGTO data	8	3600	s
$WN_{0G}$	Week Number of GGTO reference	6	1	week
<b>Total GST-GPS Conversion Size</b>		<b>42</b>		

Table 66. Parameters for the GPS Time to GST Offset Computation

When the GGTO is not available the GGTO parameters disseminated are:  $A_{0G}$  (all ones -16 bits),  $A_{1G}$  (all ones - 12 bits),  $t_{0G}$  (all ones - 8 bits),  $WN_{0G}$  (all ones - 6 bits). When a user receives all four parameters set to all ones the GGTO is considered as not valid.

### 5.1.9. Service Parameters

#### 5.1.9.1. Satellite ID

The satellite Identification is coded with 6 bits and has the characteristics given in Table 67.

Parameter	Definition	Bits	Scale Factor	Unit	Values
SVID	Satellite Identification	6	N/A	dimensionless	0...63

Table 67. Satellite ID

Note: SVID = 0 is used in the broadcast almanac data to indicate unused almanac entries. SVID values 1 to 36 are defined in this OS SIS ICD. Higher values are reserved for future use.

#### 5.1.9.2. Issue Of Data

The navigation data is disseminated in data batches each one identified by an Issue of Data. In nominal operation the navigation data (ephemeris, satellite clock correction and SISA) have limited validity duration depending on the data type. The identification of each batch by an Issue of Data (IOD) value enables:

- the users to distinguish the data in different batches received from each satellite
- to indicate to the user receiver the validity of the data (which have to be updated using new issue of navigation data)
- the user receiver to compute the full batch of data even if it misses some pages or start receiving the data somewhere during the transmission

Two IODs are defined for (Table 68):

- the ephemeris, satellite clock correction parameters and SISA
- the almanacs

Data Type	Bits	Unit
Ephemeris and Clock correction IOD <sub>nav</sub>	10	dimensionless
Almanacs IOD <sub>a</sub>	4	dimensionless

Table 68. IOD Values Mapping on Data Type

Each IOD has an associated reference time parameter disseminated within the batch.

Note: the broadcast group delay, ionospheric corrections, GST-UTC and GST-GPS conversion parameters, navigation data validity status and signal health status are not identified by any issue of data value.

#### 5.1.9.3. Navigation Data Validity and Signal Health Status

The signal health status and data validity status refer to the transmitting satellite. These status flags are used as service performance level notification (e.g. notification of satellite non availability). The navigation data validity status transmitted on E5a, E5b and E1, is coded on 1 bit, according to Table 69 and Table 70.

Parameter	Definition	Bits	Scale factor	Unit
E5a <sub>DVS</sub>	E5a Data Validity Status	1	N/A	dimensionless

Table 69. Data Validity Satellite Status (transmitted on E5a)

Parameter	Definition	Bits	Scale factor	Unit
E5b <sub>DVS</sub>	E5b Data Validity Status	1	N/A	dimensionless
E1-B <sub>DVS</sub>	E1-B Data Validity Status	1	N/A	dimensionless

Table 70. Data Validity Satellite Status (transmitted on E5b and E1-B)

The data validity status bit has the values shown in Table 71:

Data Validity Status	Definition
0	Navigation data valid
1	Working without guarantee

Table 71. Data validity Status Bit Values

The E5a signal health status transmitted on E5a-I is coded on 2 bits according to Table 72

Parameter	Definition	Bits	Scale factor	Unit
E5a <sub>HS</sub>	E5a Signal Health Status	2	N/A	dimensionless

Table 72. Signal Health Status for E5a (transmitted on E5a)

The E5b and E1-B signal health status transmitted on E5b and E1-B are coded on 2 bits according to Table 73.

Parameter	Definition	Bits	Scale factor	Unit
E5b <sub>HS</sub>	E5b Signal Health Status	2	N/A	dimensionless
E1-B <sub>HS</sub>	E1-B Signal Health Status	2	N/A	dimensionless

Table 73. Signal Health Status for E5b and E1 (transmitted on E5b and E1-B)

The signal status bits have the values shown in Table 74.

Signal Health Status	Definition
0	Signal OK
1	Signal out of service
2	Signal will be out of service
3	Signal Component currently in Test

Table 74. Signal Health Status Bit Values

#### 5.1.9.4. Checksum

The checksum, which employs a CRC technique, is used to detect the reception of corrupted data. The checksum does not include the frame synchronisation pattern or the tail bit fields since these do not form part of the required message information. For the F/NAV and I/NAV data, a CRC of 24 bits is generated from the generator polynomial  $G(X)$  described below.

$$G(X) = (1 + X) P(X) \quad \text{Eq. 22}$$

$P(X)$  is a primitive and irreducible polynomial given by the following equation.

$$P(X) = X^{23} + X^{17} + X^{13} + X^{12} + X^{11} + X^9 + X^8 + X^7 + X^5 + X^3 + 1 \quad \text{Eq. 23}$$

The CRC is composed of a sequence of 24 parity bits  $p_i$  for any  $i$  from 1 to 24,  $p_i$  is the coefficient of  $X^{24-i}$  in  $R(X)$  where:

- $R(X)$  is the remainder of the binary polynomial algebra division of the polynomial  $m(X) X^{24}$  by  $G(X)$  and
- $m(X) = m_1 X^{k-1} + \dots + m_{k-2} X^2 + m_{k-1} X + m_k$  with  $m_1, m_2, \dots, m_k$  the sequence of  $k$ -bits information to be protected by the CRC, and  $m_1$  as the MSB.

### 5.1.10. Almanac

The almanac data is a reduced-precision subset of the clock and ephemeris parameters of the active satellites in orbit. The user receiver utilises the algorithm described in paragraph 5.1.1 to compute the positions of the Galileo satellites. All other parameters appearing in the equations of Table 58, but not included in the content of the almanac, are set to zero for satellite position determination.

The Galileo almanac orbital parameters consist of

- Semi-major axis
- Eccentricity
- Inclination
- Longitude of the ascending node
- Argument of perigee
- Mean anomaly

A reduced set of clock correction parameters is provided as well in the almanac for each satellite including the time of applicability  $t_{oa}$  of the almanac data. This almanac reference time  $t_{oa}$  is referenced to the almanac reference week ( $WN_a$ ). The  $WN_a$  term consists of two bits which is a Modulo 4 binary representation of the GST week number.

Additionally, a predicted satellite health status is provided for each of these satellites, giving indications on the satellite's signal components health and navigation data health. Finally, the  $IOD_a$  allows identifying without ambiguity an almanac batch. The almanac parameters are transmitted according to the characteristics stated in Table 75.

Parameter	Definition	Bits	Scale factor	Unit
SVID	Satellite ID (1 constellation of 36 satellites)	6	1	dimensionless
$\Delta(A^{1/2})$	Difference with respect to the square root of the nominal semi-major axis (29 600 km)	13*	2 <sup>-9</sup>	meters <sup>1/2</sup>
$e$	Eccentricity	11	2 <sup>-16</sup>	dimensionless
$\delta_i$	Inclination at reference time relative to $i_0 = 56^\circ$	11*	2 <sup>-14</sup>	semi-circles***
$\Omega_0$	Longitude of ascending node of orbital plane at weekly epoch****	16*	2 <sup>-15</sup>	semi-circles***
$\dot{\Omega}$	Rate of change of right ascension	11*	2 <sup>-33</sup>	semi-circles/s***
$\omega$	Argument of perigee	16*	2 <sup>-15</sup>	semi-circles***
$M_0$	Satellite mean anomaly at reference time	16*	2 <sup>-15</sup>	semi-circles***
$a_{f0}$	Satellite clock correction bias "truncated"	16*	2 <sup>-19</sup>	s
$a_{f1}$	Satellite clock correction linear "truncated"	13*	2 <sup>-38</sup>	s/s
$E5a_{HS}^{**}$	Satellite E5a signal health status	2	N/A	dimensionless
$E5b_{HS}^{**}$	Satellite E5b signal health status	2	N/A	dimensionless
$E1-B_{HS}^{**}$	Satellite E1-B signal health status	2	N/A	dimensionless
<b>Total Satellite Almanac Size</b>		<b>131(F/NAV)</b> <b>133(I/NAV)</b>		

Parameter	Definition	Bits	Scale factor	Unit
$IOD_a$	Almanac Issue Of Data	4	N/A	dimensionless
$t_{0a}$	Almanac reference time	10	600	s
$WN_a$	Almanac reference Week Number	2	1	week
<b>Total Almanac References Size</b>		<b>16</b>		

Table 75. Almanac Parameters

- \* Parameters so indicated are two's complement, with the sign bit (+or-) occupying the MSB.
- \*\* The F/NAV almanac transmitted on the E5a-I component contains the signal health status  $E5a_{HS}$ . The I/NAV almanac transmitted on the E5b-I and E1-B components contains both signal health status  $E5b_{HS}$  and  $E1-B_{HS}$ . The two-bit health status is encoded as per Table 78.
- \*\*\* Note that the 'semi-circle' is not a SI unit but can be converted as: 1 semi-circle =  $\pi$  radian.
- \*\*\*\* More precisely,  $\Omega_0$  is the longitude of ascending node of orbital plane at the weekly epoch propagated to the reference time  $t_{0a}$  at the rate of change of right ascension.

### 5.1.11. Signal – In – Space Accuracy (SISA)

Signal – In – Space Accuracy (SISA) is a prediction of the minimum standard deviation (1-sigma) of the unbiased Gaussian distribution which overbounds the Signal – In – Space Error (SISE) predictable distribution for all possible user locations within the satellite coverage area. When no accurate prediction is available (SISA = NAPA), this is an indicator of a potential anomalous SIS.

The SISA Index shall be encoded according to the values stated in the following table.

SISA Index	SISA Value
0 ..... 49	0cm to 49cm with 1cm resolution
50 ..... 74	50cm to 0.98m with 2cm resolution
75 ..... 99	1m to 2m with 4cm resolution
100 ..... 125	2m to 6m with 16cm resolution
126 ..... 254	Spare
255	No Accuracy Prediction Available (NAPA)

Table 76. SISA Index Values

The Signal – In – Space Accuracy (SISA) shall be coded according to the values stated in the following table.

Parameter	Definition	Bits	Scale factor	Units
SISA(E1,E5a)	SISA index for dual frequency E1-E5a	8	N/A	dimensionless
SISA(E1,E5b)	SISA index for dual frequency E1-E5b	8	N/A	dimensionless

Table 77. SISA Parameters

## 5.2. SAR RLM Data

Each Return Link Message encapsulated in a SAR data page contains the following data:

- Beacon ID (60 bits):  
The Beacon ID is identical to the 60 bits (15 Hexadecimal characters) of the standard beacon identification defined in the COSPAS – SARSAT T.001 document (Specification for Cospas – Sarsat 406MHz Distress Beacons). It uniquely identifies the beacon to which the RLM is addressed.

- Message code (4 bits):  
The Message Code defines the Return Link Service according to Table 78.

RLM	Message Code (4 bits)	Return Link Service
Short-RLM	0 0 0 1	Acknowledgement Service
Short-RLM	1 1 1 1	Test Service
Short-RLM	Other codes	Spare
Long-RLM	All codes to be defined	Spare

Table 78. SAR RLM Message Code Values

- Parameters field (16 bits for the short RLM, 96 bits for the long RLM):  
The Parameters field provides the information related to the specific Return Link Service identified by the “Message Code”.  
The last bit of the Parameters field, i.e. bit 16 of the Short-RLM Parameters field and bit 96 of the Long-RLM Parameters field, is a SAR RLM data parity bit. This parity bit shall ensure that the total number of ones (1) in the fields “Beacon ID”, “Message Code” and “Parameters”, (including spare bits), is even.  
The Parameters field values for Return Link Services based on Short-RLM are defined in Table 79:

Return Link Service	Beacon Id		Message Code				Short-RLM Parameters Field																Parity		
	60		4				16																		
	Bit 1**	to Bit 60	Bit 61	Bit 62	Bit 63	Bit 64	Bit 65	Bit 66	Bit 67	Bit 68	Bit 69	Bit 70	Bit 71	Bit 72	Bit 73	Bit 74	Bit 75	Bit 76	Bit 77	Bit 78	Bit 79	Bit 80			
Acknowledgement Service - Type 1*	15 Hex Id		0	0	0	1	1	0	Spare																Parity
Test Service	15 Hex Id		1	1	1	1	Reserved																Parity		

Table 79. SAR Short-RLM Data Values

- \* Combinations of Message Code [0001] (Acknowledgement Service) with other values of bits 65–66 are spare. Refer to COSPAS–SARSAT T.001 document for the service description of the acknowledgement Type 1.
- \*\* Bit numbers are counted after concatenating the four parts of Short-RLM data described in section 4.3.7 “SAR Field Structure”. Bit 1 is received first, Bit 80 is received last.

The Parameters field values for Long-RLM are currently not defined.



## 6. Annex A - List of Acronyms

AltBOC	Constant envelope modulation scheme for combining two sidebands each consisting itself of two binary signals (in I- and Q-component).
ARNS	Aeronautical Radionavigation Services
BGD	Broadcast Group Delay
BOC	Binary Offset Carrier
CBOC	Composite Binary Offset Carrier modulation
CDMA	Code Division Multiple Access
CoP	Centre of Phase
COSPAS-SARSAT	Cosmicheskaya Sistyema Poiska Avariynich Sudov - Search and Rescue Satellite Aided Tracking
CRC	Cyclic Redundancy Check
CS	Commercial Service
DME	Distance Measuring Equipment
DN	Day Number
ECEF	Earth-Centred, Earth-Fixed
EGNOS	European Geostationary Navigation Overlay Service
FEC	Forward Error Correction
GGTO	Galileo/GPS Time Offset
GNSS	Global Navigation Satellite System
GPS	Global Positioning System
GST	Galileo System Time
GTRF	Galileo Terrestrial Reference Frame
I	In-phase signal component
ICD	Interface Control Document
ID	Identifier
IOD	Issue Of Data
ITU	International Telecommunication Union
ITU-R	ITU – Radiocommunication Sector
JTIDS	Joint Tactical Information Distribution System
LAN	Longitude of the Ascending Node
LFSR	Linear Feedback Shift Register
LSB	Least Significant Bit
Mcps	Mega chips per second
MHz	Megahertz
MIDS	Multifunctional Information Distribution System
MODIP	MODified DIP latitude
MSB	Most Significant Bit
MUX	Multiplexer
N/A	Not Applicable
NAPA	No Accuracy Prediction Available
NIB	Non-Interference Basis
NRZ	Non-Return-to-Zero
OS	Open Service
PSK	Phase-Shift Keying
Q	Quadrature Signal Component
QPSK	Quadrature Phase-Shift Keying

RAAN	Right Ascension of the Ascending Node
RF	Radio Frequency
RHCP	Right-Hand Circular Polarization
RLM	Return Link Message
RNSS	Radionavigation-Satellite Services
SAR	Search-and-Rescue Service/Signal
SI	International System of Units (Le Système international d'unités)
SIS	Signal-In-Space
SISA	Signal-In-Space Accuracy
sfu	Solar flux unit
SNF	Satellite Navigation Frame
SV	Space Vehicle
SVID	Space Vehicle IDentifier
TACAN	TACTical Air Navigation (system) equipment
TOT	Time Of Transmission
TOW	Time Of Week
TTF	Time To Fix
UTC	Coordinated Universal Time
WN	Week Number

DRAFT  
For Public Consultation

## 7. Annex B – Definitions and Nomenclature

E5-Signal	The Galileo E5-signal consists of the signals E5a, E5b (and modulation product signals) and is transmitted in the frequency band 1164 - 1215 MHz allocated to RNSS with a worldwide co-primary status. The E5-signal shares the band with the co-primary Aeronautical Radionavigation Service (ARNS) (ITU-R Radio Regulations). Moreover, it shares the band with other RNSS-signals provided by EGNOS, GPS-L5, GLONASS etc. as well as signals of the ARNS (DME, TACAN). Also found in the band is the JTIDS-MIDS signal which is permitted on an NIB.
E5a-Signal	The Galileo E5a-signal is an inherent element of the E5-signal and consists of a data-component transmitted in the in-phase component and a pilot-component transmitted in the quadrature component. The E5a-signal provides the F/NAV message supporting Galileo Open Service and overlaps (in the spectrum) with the GPS-L5-signal.
E5b-Signal	The Galileo E5b-signal is an inherent element of the E5-signal and consists of a data-component transmitted in the in-phase component and a pilot-component transmitted in the quadrature component. The E5b-signal provides the I/NAV message and supports the Open Service and the Commercial Service.
E6-Signal	The Galileo E6-signal consists of the signal components E6-B and E6-C and is transmitted in the frequency band 1215 - 300 MHz allocated on a worldwide co-primary basis (ITU-R Radio Regulations), sharing with radar systems of the radio navigation and radiolocation service. The signal components E6-B and E6-C are data-component and pilot-component respectively. The E6-signal provides the C-NAV message and supports Commercial Service.
E1- Signal	The Galileo E1-signal comprises the signal components E1-B and E1-C and is transmitted in the frequency band 1559 - 1610 MHz allocated to RNSS and ARNS on a worldwide co-primary basis (ITU-R Radio Regulations). The signal components E1-B and E1-C are data-component and pilot-component respectively. The E1-signal provides the I/NAV message and supports the Open Service and the Commercial Service.
Navigation Data Stream	Sequence of bits carrying the navigation data information by using a frame structured transmission protocol.
F/NAV Message	Navigation message provided by the E5a signal for Open Service.
I/NAV Message	Navigation message provided by E5b and E1-B signals, supporting the Open Service and the Commercial Service.
C/NAV Message	Commercial navigation message type provided by the E6-B signal supporting Commercial Service.
Data component	A data component is the result of modulating ranging code, sub-carrier (if present) and secondary code with a navigation data stream.
Pilot component	A pilot component (or dataless component) is made of ranging code, sub-carrier (if present) and secondary code only, not modulated by a navigation data stream.
Receiver reference bandwidth	The bandwidth of a hypothetical receiver with ideal (rectangular frequency response) input filters

## 8. Annex C - Galileo E1 and E5 Primary Codes

### C.1. Introduction

This annex provides the primary codes (expressed in hexadecimal format) for the Galileo Open Signal components E5a-I, E5a-Q, E5b-I, E5b-Q, E1-B and E1-C. The E5 codes are derived from LFSR sequences as described in Section 3.4.1 and provided here for convenience and completeness.

Sections C.3 to C.8 of Annex C are only provided in the electronic version of this document.

### C.2. Hexadecimal Coding Convention

Generally, one hexadecimal symbol (0,...,9, A,...,F) corresponds to four succeeding code-chips. The leftmost code-chip corresponds to the first code-chip in time, and the rightmost code-chip corresponds to the last code-chip in time. The first group is built with the first four code-chips, the second group with the fifth to eighth code-chip etc.

For primary codes whose length is not divisible by four, the last hexadecimal symbol is built from the last group of code-chips, filled up with zeros at the end in time (to the right) to reach a final length of 4 binary symbols. The translation from the chip-stream to hexadecimal symbol stream is illustrated with an example code of length 10 in Table 80.

<b>Time (in Chip)</b>	1	2	3	4	5	6	7	8	9	10	11	12
<b>Logic Representation of Chip-Values</b>	1	1	1	0	1	1	0	0	0	1	-	-
<b>Logic Representation Filled up with Zeros at the End</b>	1	1	1	0	1	1	0	0	0	1	0	0
<b>Logic to Decimal Translation</b>												
<b>Decimal Representation</b>	14				12				4			
<b>Hexadecimal Representation</b>	E				C				4			

Table 80. Example for the Translation of Logical (binary) Spreading Code into Hexadecimal Representation

Table 81 summarizes these code properties.

<b>Component</b>	<b>Primary Code Length (chips)</b>	<b>Number of Hexadecimal Symbols</b>	<b>Number of Filled up Zeros</b>	<b>Number of Defined Codes</b>
E5a-I	10230	2558	2	50
E5a-Q	10230	2558	2	50
E5b-I	10230	2558	2	50
E5b-Q	10230	2558	2	50
E1-B	4092	1023	0	50
E1-C	4092	1023	0	50

Table 81. Primary Code-Length and Hexadecimal Representation Characteristics for the Galileo Signal Components.

## 9. Annex D - Licence Agreement

By selecting the "I ACCEPT" button and/or by using, copying or distributing the OS SIS ICD IPRs or any portion thereof, YOU (the "Licensee") ACCEPT ALL TERMS AND CONDITIONS OF THIS LICENCE, including in particular the limitations on use, transferability, warranty and liability. The following terms and conditions are enforceable against you and any Affiliates that obtained and use the OS SIS ICD IPRs. If you are agreeing to these terms on behalf of a company or other legal entity, you represent that you have the legal authority to bind that company or legal entity to these terms. IF YOU DO NOT HAVE SUCH AUTHORITY OR IF YOU DO NOT WISH TO BE BOUND TO THESE TERMS DO NOT USE THE OS SIS ICD IPRs.

*The European Union (hereinafter "the EU") is the owner, co-owner with ESA, or controls the copyright and other intellectual and industrial property rights, trade secrets, and know-how related to the OS SIS ICD IPRs for which the EU is in the position to grant licence rights to third-parties.*

### 1. Definitions

1.1 The under mentioned terms printed with an initial capital letter shall have herein the following meanings unless the context otherwise requires:

"Affiliates" – means any legal entity that is under the direct or indirect control of the Licensee, or under the same direct or indirect control as the Licensee. Such control may take any of the following forms:

- a) the direct or indirect holding of 50% or more of the nominal value of the issued share capital in the legal entity concerned, or of a majority of the voting rights of the shareholders or associates of that entity;
- b) the direct or indirect holding, in fact or in law, of decision-making powers in the legal entity concerned.

"ESA" – shall mean the European Space Agency.

"Export Controls" – shall mean any international or national Export Control law or regulation applicable to the Licensee's activities under the OS SIS ICD IPRs, that regulates, embargoes or sanctions the export of products, information and/or technology in any way.

"Field of Use" – shall mean research and development on, manufacturing, commercialisation, distribution, sale, supply and maintenance of Licensee Products, which are making use of the OS Signal, by the Licensee and its Affiliates.

"GNSS" – shall mean Global Navigation Satellite System.

"Licensee Products" – shall mean software, electronic devices (e.g. chipsets and receivers), other goods and Value Added Services developed – directly or indirectly – by the Licensee by using the OS SIS ICD IPRs granted through the present Licence, which are making use of the OS Signal.

"OS Signal" – the Open Signal broadcasted by the infrastructure developed under the European GNSS Programme.

"OS SIS ICD" – the Open Service Signal in Space Interface Control Document in its latest version (available at [http://ec.europa.eu/enterprise/policies/satnav/galileo/open-service/index\\_en.htm](http://ec.europa.eu/enterprise/policies/satnav/galileo/open-service/index_en.htm)).

"OS SIS ICD Copyright" – shall mean the copyright of the OS SIS ICD document.

"OS SIS ICD IPRs" – shall mean any and all intellectual property rights contained in the OS SIS ICD and listed in Annex D.1, including but not limited to Patents and OS SIS ICD Copyright.

"Patents" – shall mean any and all patents and/or patent applications mentioned in Annex D.1, including the inventions described and claimed therein as well as any divisions, continuations, continuations-in-part, re-examinations and reissues thereof.

"Technical Data of the OS SIS ICD" – shall mean the data related to:- Galileo Signal characteristics, the Galileo Spreading Codes characteristics, Galileo Message Structure, Message Data Contents and E1 and E5 Memory Codes.

"The Territory" – shall mean the territories covered by each intellectual property right specified in Annex D.1, subject to relevant Export Control regulations.

"Value Added Services" – any service developed on the basis or by using the OS SIS ICD IPRs and delivering different or additional capabilities with respect to the OS Signal.

## 2. Subject of the Licence

2.1 The EU hereby grants the Licensee and its Affiliates a non-exclusive royalty-free licence on the OS SIS ICD IPRs, in accordance with the terms of Article 3 below and limited to the Territory and Field of Use. The Licensee shall not be entitled to grant sublicenses of any of the rights granted herein to the Licensee.

2.2 Without prejudice to Article 2.1, the commercial exploitation of the Licensee Product in the Field of Use in countries outside the Territory will be under the sole responsibility of the Licensee and its Affiliates.

## 3. Licensee's Rights and Obligations

3.1 The Licensee shall exploit the OS SIS ICD IPRs in the Field of Use in a manner so as not to harm the security interests of the EU or its Member States as set forth in article 13 and article 17 of the Regulation (EU) No 1285/2013 of the European Parliament and of the Council of 11 December 2013 on the implementation and exploitation of European satellite navigation systems and repealing Council Regulation (EC) No 876/2002 and Regulation (EC) No 683/2008 of the European Parliament and of the Council.

3.2 The EU grants the Licensee and its Affiliates the following user rights pursuant to this Licence:

- a) the right to make any use of, including the right to integrate and incorporate into any Licensee Products, the Technical Data of the OS SIS ICD and the right to store the Technical Data of the OS SIS ICD, provided the source is acknowledged;
- b) the right to reproduce the OS SIS ICD, in whole or in part, distribute it and publish it on a non-commercial scale without amending the document or adding any element, the right to place links in the Licensee and Affiliates website to the EU website where the document is published, provided the source is acknowledged, in accordance with the copyright notice in the OS SIS ICD.

- 3.3** Subject to the foregoing, Licensee shall have the right to select distributors and otherwise determine the commercial strategy, including all channels of distribution, regarding the distribution and sale of the Licensee Product in the Territory.
- 3.4** The Licensee shall be solely responsible for:
- a) exercising his rights hereunder strictly in compliance with all laws and regulations of each of the countries in which such exercise takes place;
  - b) compliance with all Export Controls regulations.
- 3.5** Terms and conditions of the present Licence shall extend without limitations to the Affiliates of the Licensee. In particular, the Licensee shall ensure that all the obligations set forth in this Licence are honoured by its Affiliates.
- 3.6** The exercise of any rights outside of the scope and extent this Licence shall be deemed in breach the intellectual property rights of the EU, ESA and any other concerned right-holders.

#### **4. Additional IPR and Maintenance of Patent Rights**

- 4.1** The EU reserves the right, in the course of the Licence term, to acquire ownership or control of additional intellectual property rights related to the OS Signal. In that case, the EU may update Annex D.1 accordingly. The additional intellectual property rights included in the updated Annex D.1 shall be considered as licensed under the present Licence, without the need to amend the Licence.
- 4.2** The EU shall have no obligation to communicate the acquisition of additional intellectual property rights related to the OS Signal to the Licensee.
- 4.3** The EU shall have no obligation to maintain the OS SIS ICD related Patents in force, whether in full or partly, nor shall it be obliged to communicate any decision thereto to the Licensee.

#### **5. Duration and Termination**

- 5.1** This Licence shall be valid for the whole duration of the OS SIS ICD IPRs licensed hereunder insofar as the terms and conditions of this Licence are respected by the Licensee.
- 5.2** This Licence and the rights granted hereunder will terminate automatically upon any breach by the Licensee of the terms of the Licence.
- 5.3** In the event of termination howsoever occurred the Licensee shall:
- a) discontinue the use of the Licensee Products or any other activity covered under Article 2,
  - b) take all appropriate measures to minimize costs, prevent damage, and cancel his commitments and
  - c) have the right, within 6 months after the termination of the present Licence, to sell all remaining Licensee Products at that date in stock, or to finish and fulfil all agreements which have been entered into prior to the declaration of the termination.
- 5.4** This Licence and its validity shall not be influenced by the fact that one or more of the licensed OS SIS ICD IPRs should finally be declared not granted or invalid.

## **6. Liability**

- 6.1 The EU and ESA make no representation as to the patentability and/or breadth of the OS SIS ICD IPRs licensed under the present Licence, except for the material existence of the Patent. The EU and ESA assume no liabilities concerning:
- a) any third party's prior rights to use the OS SIS ICD IPRs,
  - b) the dependency of the OS SIS ICD IPRs on third parties' intellectual property rights.
- 6.2 The Licensee and its Affiliates shall keep the EU and ESA harmless in respect to any infringement of any patent or other right of third parties due to the Licensee's activities under this Licence.
- 6.3 The EU makes no express or implied warranties as to the merchantability or fitness for a particular purpose of the OS SIS ICD IPRs. To the full extent allowed by law, the EU and ESA disclaim all warranties, whether expressed or implied, for any claim related to the use of OS SIS ICD IPRs by the Licensee, its contractors or Affiliates, or related to the Licensee Product, including on product liability.

## **7. Infringements by Third Parties**

- 7.1 The Parties hereto shall inform each other promptly of any act of infringement, passing-off, unfair competition or the like, or suspected or threatened such act, any challenge or any allegation or complaint by a third party in relation to use or intended use of the OS SIS ICD IPRs in the Territory which are subject to this Licence.
- 7.2 The EU and ESA reserve the right and faculty to decide whether or not to bring an action for any infringements of the OS SIS ICD IPRs, even where the EU has been duly informed about such alleged infringement by the Licensee. The EU shall have no obligation to notify any decision thereto to the Licensee.

## **8. Action for Infringement Brought by Third Parties**

- 8.1 If actions for infringement are brought against the Licensee as a result of the exploitation of the OS SIS ICD IPRs, the costs incurred for its defence and payment of damages shall be borne by the Licensee. The Licensee undertakes without undue delay to notify the EU about any action brought against the Licensee as a consequence of the exercise by the Licensee of the rights granted herein. The EU may, at its sole discretion, agree to provide the Licensee with any assistance which the EU considers to be appropriate.

## **9. Intellectual Property Rights**

- 9.1 OS SIS ICD IPRs are the exclusive property of the EU and/or ESA respectively, as indicated in Annex D.1.
- 9.2 The Licensee acknowledges that ownership in the OS SIS ICD IPRs as described in Annex D.1 shall remain with the respective owners and that, therefore, the Licensee shall not acquire title of any intellectual property right on the OS SIS ICD IPRs under the present Licence. Pending the duration of the present Licence, the Licensee shall not challenge the validity of OS SIS ICD IPRs, or support third parties in such a challenge.



## 10. Indemnification

- 10.1** Subject to Article 10.2, the Licensee shall defend at its own expense any claim, suit or proceeding brought against the Licensee, insofar as it arises from the Licensee's use of the OS SIS ICD IPRs
- 10.2** In the event any claim, suit or proceeding is brought against the Licensee based on a claim that any portion of the OS SIS ICD IPRs constitutes an infringement of patent or copyright, or other intellectual property rights of any third party arising under the applicable law, the EU (and/or ESA, in relation to the OS SIS ICD IPRs they respectively own) shall have the right at their option to assume the defence of such action. In such event, the EU shall pay all damages, costs and expenses finally awarded to the third parties against the Licensee but shall not be responsible for any compromise made without its consent.

## 11. Permits

- 11.1** The necessary steps for obtaining all permits and licences required for the implementation of this Licence, under the laws and regulations in force at the place where the commercial activities of the Licensee are to be provided, shall be the exclusive responsibility of the Licensee.

## 12. Applicable Law and Arbitration

- 12.1** This Licence shall be governed by European Union law, complemented where necessary by the law of Belgium.
- 12.2** Any dispute, controversy or claim arising under, out of or relating to this Licence and any subsequent amendments thereof, including, without limitation, its formation, validity, binding effect, interpretation, performance, breach or termination, as well as non-contractual claims, shall be submitted to mediation in accordance with the WIPO Mediation Rules. The place of mediation shall be Brussels. The language to be used in the mediation shall be English.
- 12.3** If, and to the extent that, any such dispute, controversy or claim has not been settled amicably and one of the parties to this Licence so notifies the other in writing, such effort shall be deemed to have failed. In that case, each party may initiate proceedings before the General Court in Luxembourg, subject to an appeal to the Court of Justice of the European Union.

## 13. Miscellaneous

The invalidity of a provision of this Licence is not fundamental to its performance, the validity and enforceability of the remaining provisions hereof shall not in any way be affected thereby, it shall not relieve the Licensee of its obligations under the remaining provisions of this Licence.

## 14. Annexes

- 14.1** The following are appended to and are an integral part of this Licence:
- Annex D.1: List of OS SIS ICD-related Intellectual Property Rights

{I ACCEPT}

{I DO NOT ACCEPT}

## Annex D.1 - List of OS SIS ICD Related Intellectual Property Rights

IPR	Name of IPR	Patent/ Trademark number	Date of filing	Date of publication	Applicant	Owner	Application number	Type of applicant	File reference	Territorial coverage
1	Patent Multi-band antenna for satellite positioning system	WO2007006773	10/07/2006	18/01/2007	GSA	EU	PCT/EP2006/06 4067	International / European	P-2744	Australia Canada Norway USA S.Korea China India Japan Russia
2	Patent Method for providing assistance data to a mobile station of a satellite positioning system	WO2007054493	07/11/2006	18/05/2007	GSA	EU	PCT/EP2006/06 8177	International / European	P-2745	Australia Canada Europe designated countries: (AT,BE,CH ,CZ,DE,DK,ES,FI,FR,G B,GR,HU,IE,IT,LU,NL, PL,PT,RO,SE,TR) USA S.Korea China India Japan Russia
3	Patent Method and generator for generating a spread-spectrum signal (initially referred to as Use of antiphase CBOC (6.1) modulation to improve ranging accuracy in satellite navigation signals)	Not yet granted	20/04/2007	09/05/2007	GSA	EU	11738006	USA	P-2764/US	USA
4	Patent Method and generator for generating a spread-spectrum signal	Not yet granted	15/09/2009	25/03/2010	GSA	EU	12559874	USA	P-2764/ US-DIV	USA
5	Patent Chaotic spreading codes and their generation	91 292	01/12/2006	-	GSA	EU	91 292	Luxembourg	P-2784/LU	Luxembourg

IPR	Name of IPR	Patent/ Trademark number	Date of filing	Date of publication	Applicant	Owner	Application number	Type of applicant	File reference	Territorial coverage
5	Patent Chaotic spreading codes and their generation	WO2008065191	30/11/2007	05/06/2008	GSA	EU	PCT/EP2007/06 3080	International / European	P-2784	Australia Brazil Canada China Europe designated countries: (AT,BE,B G,CH,CY,CZ,DE,DK,E E,ES,FI,FR,GB,GR,H U,IE,IS,IT,LT,LU,MC ,NL,PL,PT,RO,SE,SI, SK,TR) India Japan S.Korea Russia USA Worldwide
6	Copyright co-ownership with ESA	NA	NA	NA	NA	EU and ESA	NA	NA	NA	Worldwide
7	Patent Spreading codes for a satellite navigation system (concerning memory codes)	WO2006063613 EP not yet granted	17/12/2004	22/06/2006	ESA	ESA	PCT/EP2004/01 4488	International	ESA/GAL/ PAT/003	Canada Europe designated countries: (AT,BE,B G,CH,CY,CZ,DE,DK,E E,ES,FI,FR,GB,GR,H U,IE,IS,IT,LT,LU,MC ,NL,PL,PT,RO,SE,SI, SK,TR) USA Brazil China Japan
8	Patent Spreading codes for a satellite navigation system (concerning secondary Codes)	WO2007003213 EP granted 26/08/2009	01/07/2005	11/01/2007	ESA	ESA	PCT/EP2005/00 7235	International	ESA/GAL/ PAT/004	Canada Europe designated countries: (BE,CH,C Z,DE,ES,FI,FR,GB,GR ,HU,IE,IT,LU,MC,NL,P T,SE,TR) USA Brazil China Japan

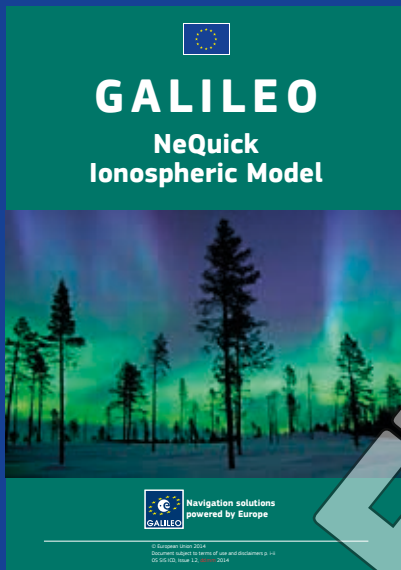

Front covers of other Galileo technical documents

Front covers of other Galileo technical documents



Navigation solutions powered by Europe